

THE SUBMARINE REVIEW



NUCLEAR DETERRENCE

Commander, US Strategic Command
ADM Cecil Haney, USN9

Strategic Stability
Ms. Rose Gottemoeller
Under Secretary for Arms Control20

The Strategic Nuclear Enterprise:
Implementing the Roadmap Ahead
RDML Joe Tofalo, USN.....27

Prudent Alternative to Minimum
Deterrence
Dr. Keith Payne and
Ambassador Robert Joseph35

SHIPBUILDING and FORCE LEVEL

Future Undersea Imperatives for
Integrated Navy
RADM Rick Breckenridge, USN.....49

Navy Force Structure & Shipbuilding–
Excerpts
Mr. Ron O'Rourke.....89

FEATURES

Uranium Enrichment and the Nuclear
Fuel Cycle
VADM Paul Sullivan, USN, Ret. and
Mr. John Welch112

Rickover's Leadership & Rise of the
Nuclear Navy A Chapter from
Against the Tide
RADM Dave Oliver, USN, Ret......123

Sinking the Glomar Explorer in 1974
CAPT Jack O'Connell, USN, Ret.138

Submarine News from Around
the World
AMI Hot News.....142

THE SUBMARINE COMMUNITY

Speech to 298th Basic Enlisted SubScol
Class (1964)
CAPT R. E. Thomas, USN, Ret.149

BOOK REVIEW

Cold War Command: Dramatic Story of
a Nuclear Submariner by
CAPT Dan Conley, RN *Reviewed by*
CAPT Jim Patton, USN, Ret.153



ADVANCED ELECTRONIC
SYSTEMS SOLUTIONS

***THE VALUE OF
CONNECTING
INNOVATION
AND
AFFORDABILITY.***

Northrop Grumman is proving that affordability and effectiveness can go hand in hand. Our innovative, agile approach to product optimization ensures that your needs are met within budget, delivering high quality on a shorter schedule. *That's why we're a leader in adaptable, affordable solutions.*

THE VALUE OF PERFORMANCE.

NORTHROP GRUMMAN

[www.northropgrumman.com](http://www.northropgrumman.com/es)
/es

EDITOR'S COMMENTS

The delay in this issue of THE SUBMARINE REVIEW is not due to collection nor production problems but is exclusively editorial in nature. My attention and personal time for a period of several weeks were diverted to a family medical problem. So it's not the system which is at fault.

In spite of human factors, however, the magazine continues with emphasis on the two main concerns facing the submarine community. The first concern is to support a strong national Nuclear Deterrence policy; therefore to counter current arguments against the long-delayed modernization of our strategic nuclear forces and supporting facilities. The second critical concern is for support of the Submarine Force's building program, headlined by the OHIO Replacement Program.

There is an obvious parochial connection between those two concerns. A shift in current national direction from a strong Nuclear Deterrence Policy could put in doubt funding for the replacement SSBNs. But we at the delivery end of deterrence know that credible deterrence consists of sufficient force capability and the national will to use it if necessary. This is a logic and philosophy fight which may be driven for some by fiscal concerns, but it can be addressed by an informed citizenry willing to spread the perceived wisdom.

Each of those concerns is addressed in this issue. The lead section is about Nuclear Deterrence and carries several current policy statements on the subject. The second section deals with Naval Shipbuilding and Force Levels. Instead of outlining each of the presentation/articles I will point out partial pieces in each major section for particular attention. In the Prudent Alternative to Minimum Deterrence please look for the more complete recognition of what Deterrence is really about. In Rear Admiral Tofalo's presentation note his arguments for special funding of the OHIO Replacement Program.

In the extracts of Mr. Ron O'Rourke's report on naval shipbuilding one can see that the out-years shortfall in SSNs is not the



only Navy force-level problem. It is my opinion that more importantly, however, we should give careful attention to the last part of that piece, his Annex C to the basic report. It is a wonderfully concise and pointed summary of why the US needs a Navy. By logical extension that also says “Why Submarines?”

Jim Hay
Editor

FROM THE PRESIDENT

As this edition of THE SUBMARINE REVIEW goes to press, there is a great deal of change in the air. The elections in November 2014 are certain to exacerbate an already complex budget environment within the Congress and the recently announced resignation of the Secretary of Defense will undoubtedly add to the challenge of aligning limited resources to address current and future requirements.

In the midst of all the goings on in Washington, DC, the U.S. Submarine Force continues to provide exceptional value to our nation in a demanding and dynamic time. Around the world, forward deployed U.S. submarines provide valuable support while addressing diverse and dynamic operational demands. Our strategic deterrent and attack submarines excel while meeting the highest standards of maintenance, training, and operations at sea, supporting Combatant Commanders in every theater.

Our Submarine Force leadership continues to provide clear, steady, and concise direction for our operational forces and the industrial base that supports them. Our nation's submarines and our submariners are building on the legacy of those who went before them and their performance continues to be superb.

Our strategic deterrent force recently completed its 4000th patrol, a remarkable record of superior performance, sustaining a vigilant and stabilizing posture in a most uncertain world. These exceptional men and women go about their business with quiet determination, meeting the highest professional standards in the execution of their critical mission.

We have included the thoughts of ADM Cecil Haney, RADM Rick Breckenridge and RADM (Sel) Joe Tofalo in this issue of THE SUBMARINE REVIEW to inform and frame the discussion about the nation's need to invest in the modernization of the most survivable leg of our strategic TRIAD. The OHIO Replacement Program (ORP), our Navy's top shipbuilding priority, will require diligent oversight and skillful execution in order to meet a demanding schedule. Meeting this schedule is critical if we are to meet our strategic operational requirements and execute the first



deterrent patrol in 2031 with no gap in our Navy's required strategic presence as the OHIO Class submarines retire from service.

To ensure best value, the ORP focuses on three specific areas for efficiency and cost reduction: 1) Design for Affordability, ensuring that the ORP design and engineering optimize and improve upon the highly successful practices in use throughout the VIRGINIA Class Submarine Program, 2) Design for Producibility, ensuring that ORP production and construction techniques and practices optimize and improve upon those used during the construction of the VIRGINIA Class Submarines, and 3) Design for Sustainability, ensuring that life cycle costs for these ships are minimized over their service life in support of our Navy's essential strategic deterrent mission.

As previously noted in these pages, this critical program enjoys strong funding support in Congress and throughout the Navy and the execution of the design and engineering plan is on track to support construction start in 2021.

Our attack submarines are operating forward deployed around the world, bringing exceptional combat capability and persistent covert presence to every maritime theater in response to the myriad demands of our Combatant Commanders. The Submarine Force maintenance and modernization plan ensures that all of our deployed attack submarines are able to employ tactically relevant combat capability when needed, for as long as needed.

VIRGINIA Class submarines are demonstrating their value in every theater of operation and the VIRGINIA Class Program is the top performing program within the Department of Defense. USS NORTH DAKOTA (SSN-784) was commissioned earlier this year, ahead of schedule and under budget. USS JOHN WARNER (SSN-785) has been christened, and USS ILLINOIS (SSN-786) and USS WASHINGTON (SSN-787) are on track to sustain this superior performance.

The Naval Submarine League has enjoyed strong support from our Corporate Sponsors and the Submarine Force leadership team. Our annual symposium in October provided a forum for leadership to speak and for the industrial base to engage. As we move

forward in these most interesting times, it is clear that an informed dialogue will be key to ensuring that thoughtful and responsible choices are made. THE SUBMARINE REVIEW will continue to inform Naval Submarine League members as they are engaged in critically important discussions about our nation's security and the submarine force needed to ensure sustained undersea dominance in a complex and rapidly changing world.

Your support, and the support of all of our Corporate Members, provide critical elements necessary for the sustainment of the Naval Submarine League's effort to promote a robust and effective U.S. Submarine Force within the U.S. Navy. Your support allows the Naval Submarine League to articulate the value, effectiveness, and professionalism of our Submarine Force and our submarine industrial base as our nation addresses current and future challenges.

As the first winter storm of 2014 hits the I-95 corridor at the beginning of the Thanksgiving holiday travel rush, I wish you all a happy holiday season and a steady budget forecast for the new year.

John B. Padgett III
President

THE SUBMARINE REVIEW

THE SUBMARINE REVIEW is a quarterly publication of the Naval Submarine League. It is a forum for discussion of submarine matters, be they of past, present or future aspects of the ships, weapons and men who train and carry out undersea warfare. It is the intention of the **REVIEW** to reflect not only the views of Naval Submarine League members but of all who are interested in submarining.

Articles for this magazine will be accepted on any subject closely related to submarine matters. Article length should be no longer than 2500 to 3000 words. Subjects requiring longer treatment should be prepared in parts for sequential publication. Electronic submission is preferred with MS Word as an acceptable system. If paper copy is submitted, an accompanying CD will be of significant assistance. Content, timing and originality of thought are of first importance in the selection of articles for the **REVIEW**.

A stipend of up to \$200.00 will be paid for each major article published. For shorter Reflections, Sea Stories, etc., \$100.00 is usual. Book reviewers are awarded \$52.00, which is that special figure to honor the U.S. submarines lost during World War II. Annually, three articles are selected for special recognition and an additional honorarium of up to \$400.00 will be awarded to the authors. **Articles accepted for publication in the REVIEW become the property of the Naval Submarine League.** The views expressed by the authors are their own and are not to be construed to be those of the Naval Submarine League. In those instances where the NSL has taken and published an official position or view, specific reference to that fact will accompany the article.

Comments on articles and brief discussion items are welcomed to make **THE SUBMARINE REVIEW** a dynamic reflection of the League's interest in submarines. The success of this magazine is up to those persons who have such a dedicated interest in submarines that they want to keep alive the submarine past, help with present submarine problems and be influential in guiding the future of submarines in the U.S. Navy.

Articles should be submitted to the Editor, SUBMARINE REVIEW, 5025D Backlick Road, Annandale, VA 22003.

FOR OVER 30 YEARS
Applied Mathematics has provided
objective analysis for the Submarine Force
in support of submarine warfare

- **SEARCH TACTICS • TARGET MOTION ANALYSIS**
- **TACTICAL DECISION AIDS**
- **TACTICAL DEVELOPMENT & EVALUATION**

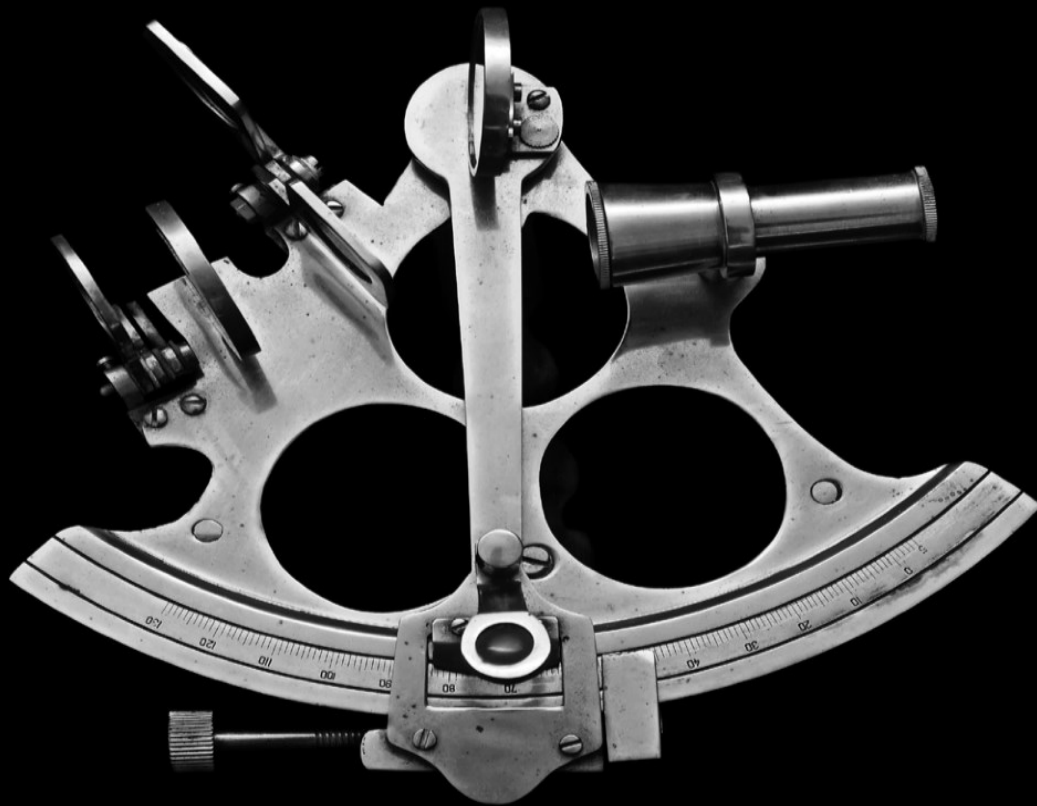

APPLIED MATHEMATICS, INC.

Gales Ferry, Connecticut | www.applmath.com

THE SUBMARINE REVIEW IS A PUBLICATION OF THE NAVAL SUBMARINE LEAGUE
COPYRIGHT 2014

OFFICERS OF THE NAVAL SUBMARINE LEAGUE

President: RADM John B. Padgett III, USN, Ret.
Vice President: VADM John J. Donnelly, USN, Ret.
Executive Director: CAPT Tim Oliver, USN, Ret.
Secretary: RADM Phil Davis, USN, Ret.
Treasurer: CAPT R. C. Wagoner, USN, Ret.
Counsel: CAPT Earl Griggs, USN, Ret.

BOARD OF DIRECTORS OF THE NAVAL SUBMARINE LEAGUE

Chairman: ADM Rich W. Mies, USN, Ret. Mr. Peyton S. Baker ADM Frank L. "Skip" Bowman, USN, Ret. VADM Dan L. Cooper, USN, Ret. (Emeritus) RADM Phil Davis, USN, Ret. ADM Bruce DeMars, USN, Ret. (Past Chairman) ADM Kirkland H. Donald, USN, Ret. VADM John J. Donnelly, USN, Ret. RADM Frank M. Drennan, USN, Ret. VADM George W. Emery, USN, Ret. Mr. John Fox Mr. Jeffrey S. Geiger Mr. Jack M. Gellen RADM David A. Gove, USN, Ret.	VADM Bud M. Kauderer, USN, Ret. (Emeritus) RADM Al L. Kelln, USN, Ret. (Emeritus) Mr. Walter P. Kitonis III Ms. Teri G. Marconi Mr. Matthew J. Mulherin RADM John B. Padgett III, USN, Ret. Mr. Roger Sexauer ADM William D. Smith, USN, Ret. (Emeritus) VADM Stan R. Szemborski, USN, Ret. ADM Carl A. H. Trost, USN, Ret. (Emeritus) Mr. Dan Tyler CAPT Tom Vecchiolla, USN, Ret. CAPT R. C. Wagoner, USN, Ret. MCPON Rick D. West, USN, Ret. RADM Charlie Young, USN, Ret.
---	---

LIAISONS

VADM Michael J. Connor, USN FORCM (SS) Wes Koshoffer, USN	RDML Joseph Tofalo, USN FORCM (SS) Russell Mason, USN
--	--

ADVISORY COUNCIL OF THE NAVAL SUBMARINE LEAGUE

Chairman: VADM Steve Stanley, USN, Ret. CAPT Mark Bock, USN, Ret. Ms. Beci Brenton RDML Fred Byus, USN, Ret. Mr. John Cottrell	CAPT Jim Durham, USN, Ret. RADM Jerry Ellis, USN, Ret. Mr. Jim Hughes VADM Albert H. "Al" Konetzni, USN, Ret. RADM Joseph Walsh, USN, Ret.
---	--

STAFF OF THE SUBMARINE REVIEW

Editor: CAPT James C. Hay, USN, Ret.
Assistant Editor: Mrs. Kristin N. Bernacchi

EDITORIAL REVIEW COMMITTEE OF THE SUBMARINE REVIEW

Dr. Bill Browning RDM.L Fred Byus, USN, Ret. CAPT Bill Clautice, USN, Ret.	CAPT Jim Collins, USN, Ret. CAPT George Graveson, USN, Ret. CAPT Tim Oliver, USN, Ret.
--	--

Corporate Affairs: VADM Albert H. "Al" Konetzni, USN, Ret.
History Chairman Chair: CAPT David A. Rosenberg, USN, Ret.
Subtech Symposium Chairman: RADM Charlie Young, USN, Ret.

CHAPTER PRESIDENTS OF THE NAVAL SUBMARINE LEAGUE

ALOHA: CAPT Jerry Hofwolt, USN, Ret.
ATLANTIC SOUTHEAST: CAPT Mark Kevan, USN, Ret.
CAPITOL: CAPT Brad Kratovil, USN, Ret.
HAMPTON ROADS: CAPT David C. Knapp, USN, Ret.
LEVERING SMITH: CAPT Harry Sheffield, USN, Ret.
NAUTILUS: CAPT Dennis McKelvey, USN, Ret.
NORTHERN CALIFORNIA: LT. Owen Brooks, USN
PACIFIC NORTHWEST: CAPT Howard Trost, USN, Ret.
PACIFIC SOUTHWEST: CAPT Sibley L. Ward III, USN, Ret.
SOUTH CAROLINA: CAPT Rusty Pickett, USN, Ret.

OFFICE STAFF

Executive Director: CAPT Tim Oliver, USN, Ret.
Membership Records: Mrs. Deb Del Rossi **Event Coordinator:** Mrs. Kristin Bernacchi
Admin Assistants: Mrs. Martha Richardson and Mrs. Ellen Brunk



***THE VALUE OF
AN ENDURING
COMMITMENT
TO THE ENTIRE
NAVAL FLEET.***

NAVAL AND
MARINE SYSTEMS

**NORTHROP GRUMMAN:
A TRUSTED AND CRITICAL
PARTNER TO THE U.S. NAVY.**

Whether it's designing
Submarine and Aircraft
Carrier Power Generation
Programs, Integrated
Navigation and Control
Systems, Large S-Band
Radars, or Mine Warfare
Systems, Northrop Grumman
has long provided the
U.S. Navy with innovative,
affordable solutions.

*That's why we're a leader
in Naval and Marine Systems.*

THE VALUE OF PERFORMANCE.

NORTHROP GRUMMAN

[www.northropgrumman.com
/naulmarine](http://www.northropgrumman.com/naulmarine)

**MINOT TASK FORCE 21 CONFERENCE ON
“THE STRATEGIC NUCLEAR ENTERPRISE:
IMPLEMENTING THE ROADMAP AHEAD”**

**LUNCHEON KEYNOTE ADDRESS WITH
ADMIRAL CECIL HANEY
COMMANDER,
UNITED STATES STRATEGIC COMMAND**

SEPTEMBER 18, 2014

MR. HUESSY: We are honored indeed to have the Commander of U.S. Strategic Command, former Commander of the Pacific Fleet, Admiral Cecil Haney, who is here today to speak with us. He’s a graduate of the Naval Academy in 1978. He is here to share with us his views of where we are with respect to strategic nuclear modernization and the roadmap ahead. Admiral, I want to thank you again for speaking earlier this year at my breakfast series, and thank you for coming here and being our keynote speaker for lunch. It’s certainly an honor to have you here.

Would you please welcome our Commander of U.S. Strategic Command, Admiral Cecil Haney?

ADM. CECIL HANEY: Thanks, Peter, for that kind introduction, and good afternoon. There are good tactical positions and there are some that are not so good. Usually speaking after lunch is not so good.

Also sometimes speaking where you have former bosses in the room is also not too good because then they’re going to critique your performance. But, it’s all good. And I’m glad that a number of professionals that I knew are assembled here for this conference. I really thought I’d start off just by saluting your efforts. I can’t thank you enough for all you do ...relative to this important business of the United States of America ...maintaining and

sustaining its credible, safe, secure and effective strategic deterrent.

And of course this forum is pretty timely in terms of this afternoon Administrator Frank Klotz, who I think you heard from, and the lab directors and myself will address the House Armed Services Committee in a classified setting associated with our stockpile. And I would be remiss if I didn't start off this session with saluting and acknowledging that this is the 67th birthday of our United States Air Force. In a short 67 years the Air Force has stood strong in the defense of our nation and has revolutionized, many of the capabilities we take for granted today: dominant airpower, space and cyberspace capabilities, to mention a few, and of course their contribution to strategic deterrence, representing two-thirds of our nation from a triad platform perspective. So happy birthday, United States Air Force.

Now I did note that Admiral Donald is here. He used to be my boss from the naval reactors standpoint.

But some deficiency was noted, because I was expecting before coming up to the podium that we'd have a cake, since it was the Air Force's birthday.

I'm still looking for that cake. Maybe I'll get my cake later because when I had my VTC (video teleconference) with my command earlier this morning, and we were talking about Air Force birthday, they did tell me that they were having a cake without me today.

It is always difficult following such an elite lineup as you've had of guest speakers this morning. And given the intellect and experience of this crowd, I know you've had many rich conversations associated with the topics and the speakers that you've had thus far. I will advertise up front that I am looking forward to your questions as I conclude my formal remarks.

Before I get started, though, I want to thank Task Force 21 for hosting this event. I was fortunate to meet some of its members as they visited my headquarters back in July. We had a rich conversation there, so it's great to see Mark Janser again, and of course you and the other members of your team that are here with you. I can't thank them enough for the dedication that they

provide, and interest associated with our strategic deterrent mission, and the endless support they provide our Minot community of warriors and, of course, their families.

I want to also thank Peter here publicly for his continued efforts in supporting important opportunities like this one, providing a venue that allows us to come together and discuss strategic issues of importance to our nation. For 21 years you've brought members of this community together to not only inform, but to spark debate amongst us on weighty topics associated with the necessity to maintain a credible strategic deterrent.

While it is important to bring us together to discuss triad issues, it's equally important we holistically tie the enterprise together. Most of you have heard me say that strategic deterrence is more than the triad of platforms. It also includes a robust and agile intelligence apparatus that can provide the necessary indications of warning. It's the system of dedicated space and ground sensors that provide critical early warning of missile launches and bomber threats, assured nuclear and national command and control communications to use that information, and the necessary infrastructure to sustain nuclear weapons without testing the warheads.

A credible missile defense system is also a part of that. It defends against limited attacks from rogue nations such as Iran and North Korea. It takes all of the relevant space and cyberspace capabilities, trained and ready people to conduct strategic operations and planning, synchronized treaties, policies and strategies, and of course a campaign plan that orients all of our assigned capabilities and activities to a common daily purpose, to deter a strategic attack and reassure our allies.

These areas are inter-related and connected. To be successful in future efforts we must leverage these capabilities in an integrated manner, understanding how they influence each other and how they connect across multiple domains. And it will require us to take a responsive whole of government approach working, of course, closely with our allies and partners.

So while the diversity of U.S. Strategic Command's missions allow us to maintain a global perspective, ensuring a safe, secure

and effective nuclear deterrent force remains a core responsibility, as stated in the Nuclear Posture Review, and retains an important role in our country's defense. For the foreseeable future, the nuclear enterprise will remain foundational to strategic deterrence. And as you all know, last year the president released his nuclear weapons employment strategy which stated that retaining all three legs of the nuclear triad would best maintain strategic stability at reasonable cost, while hedging against potential technical problems or vulnerabilities.

Each distinct but complementary component of these strategic capabilities is vital to our deterrent mission, as well as to those nations around the world that count on and depend on us for extended deterrence. This collection of capabilities also represents an insurmountable challenge for any adversary to overcome. It provides the president of the United States with flexible responsive options and adequate decision space should deterrence fail.

While I am confident in our capabilities today, there are of course risks that we must balance and prioritize in a way that enhances national security. And I would like to address three of these with you today. First, number one is external; two, systematic aging of weapons platforms and infrastructure; and three, budgetary constraints.

So first, is the external risk, a geopolitical surprise. As DNI Clapper said in January, quote, "The time when only a few nations had access to the most dangerous weapons is long past," end-quote. But as you know, it's not just nuclear threats that we should be concerned about.

There are multiple actors operating across multiple domains, investing in their space and cyberspace capabilities, which are growing in scale and of course sophistication. As a country, we depend on space, as do other nations around the world. So it's very problematic to see countries, such as China, conducting missile tests designed to destroy satellites, as we just saw back in July. Thankfully, this time, it didn't hit anything. You may recall back in 2007 the anti-satellite test that China conducted created thousands of pieces of debris that continues to endanger the space systems of all nations.

Cyber is another area that we as a country must continue to work hard at, as today's threats are both immediate and evolving. The news today highlights that even violent extremist organizations are using cyber to recruit, to message, and to deliver effects. You may have heard in my discussions with Congress and other venues that I see increasing strategic risk as potential adversaries advance their mobile, global reach capabilities with cyber, counter-space and nuclear weapon capabilities.

While I hope that direct military conflict with nation states with weapons of mass destruction remains remote in the near horizon, perhaps, as I look at things like Russia in Ukraine, which I'm sure most of you are following also daily, stepping back reveals an unfolding of nationalism deeply rooted in Russian history. Some in Russia share President Putin's assessment that the breakup of the Soviet Union was quote, "the greatest geopolitical catastrophe of the 21st century," end-quote. And while both the United States and Russia recently reaffirmed their commitment to the Intermediate-range Nuclear Forces Treaty, President Putin continues to stress the importance of Russia's nuclear arsenal as an equalizer.

You may have seen footage on YouTube of President Putin ordering Russian nuclear forces to conduct two strategic exercises in the past year, and more are likely to be observed in the future. They have a decade plus of modernization across each leg of their triad; for example, a new submarine and associated submarine-launched ballistic missile, a new air-launched cruise missile, and more advanced mobile intercontinental ballistic missiles. China is also modernizing their strategic forces to include fielding more survivable road-mobile intercontinental ballistic missiles, enhancing their silo-based ICBMs, as well as developing and deploying a new ballistic missile submarine.

More and more strategic nuclear capabilities are going mobile. I could talk at length regarding the ambitions of Kim Jong-un of North Korea and his aspirations to develop an advanced nuclear capability, or Iran's desires for nuclear weapons, or the modernization efforts associated with India and Pakistan. We should not lose sight that many terrorist groups continue to have aspirational

desires to acquire weapons of mass destruction. Their mobility will likely be through nontraditional delivery means. That will be a different challenge.

As the report on Nuclear Weapons Employment Strategy states, quote, “We must assume they would use such weapons if they manage to attain them,” end-quote. Given the brutality of their movement, as we have seen recently with ISIL and Boko Haram, we should expect that given the opportunity these groups will have, and in many cases are already displaying, their propensity to behave in ways that are unconstrained by international norms.

The second risk is our aging weapons, platforms and supporting infrastructure. We cannot afford a technical failure that renders a leg of the triad unreliable. We have sustained and will continue to sustain our platforms and weapons, but the sustainment efforts cannot last forever, which necessitates moving forward with modernization.

To work through some of these very complex issues, U.S. Strategic Command recently hosted a ballistic missile submarine, and separately an intercontinental ballistic missile, stakeholder meeting. It was extremely valuable to meet with the leaders of these communities, who fully understand our corporate challenges and are committed to charting the best way forward. We had some very, very frank discussions on how best we can sustain and modernize today’s platforms and components. And I look forward to having similar discussions with our bomber leadership at the end of October.

Tomorrow, I will be in Kings Bay, Georgia as our nation celebrates its 4,000th strategic deterrent patrol. What an important milestone for our nation. The Ohio-class ballistic missile submarine has been extended beyond its original 30-year service life to an unprecedented 42 years, longer than any ballistic missile submarine in the history of the United States.

But let’s not take that for granted. We have reached the point where no margin exists to extend the Ohio-class and we can ill afford to delay the Ohio replacement program any further. This is my number one priority, the CNO’s top acquisition priority, and

it's critically important that we move forward with this program. As such, the U.S. Strategic Command is working very closely, of course, with the Navy, the Joint Staff and the Office of the Secretary of Defense to keep the Ohio replacement program on track.

Our ICBM force promotes deterrence and stability. And as I witnessed firsthand last week during a visit to Malstrom Air Force Base, our missileers, our maintainers and security forces operate and maintain and secure these platforms with professionalism, dedication and passion 24/7. I'm really happy that we have some of them here at the table. Why don't you guys stand up to be recognized?

Thank you for your service to our country. And even though we have our best Airmen such as these conducting this mission, there are challenges we must work through. Our foremost challenge is addressing the Minuteman III near- and mid-term sustainment. We must take a system of systems approach similar to that taken by our submarines and aircraft and review the system holistically. The timing also requires us to execute an intercontinental ballistic missile recapitalization strategy that will carry us beyond 2030.

As I'm sure General Seve Wilson probably talked about, the Air Force is conducting an analysis of alternatives for the ground-based strategic deterrent. This will help in the development of the requirements to ensure our ICBM capabilities stay viable for decades to come.

Our aging B-52 and B-2 fleet continues to demonstrate their global presence and agility through involvement in numerous multi-national exercises, through continuous bomber presence in the Western Pacific, and their deterrence and assurance missions around the globe. Of course, as you know, our B-52 Hotel models are more than 50 years old, and our B-2s are already 20 years old. While we are initiating and executing required upgrades and life extension activities to meet current nuclear and conventional mission requirements, we are reaching a point where the nation needs a new long-range strike platform.



To preserve the ability to adapt to future challenges, we must continue to pursue a new highly survivable penetrating bomber that will hold any target on earth at risk and provide operational flexibility across a wide range of military actions. To continue to provide a long-range strike capability, the B-61 life extension program and a new long-range strike option weapon is necessary, as the air-launched cruise missile reaches its end of service life around the 2030 period.

The aviators in the audience—I'm sure I have some here—understand that the global reach of our nuclear and conventional bombers are assured by our airborne refueling assets. This capability was demonstrated to me recently on a flight I took with the talented men and women of the 126th Air Refueling Unit. It was good also to see the momentum of the new KC-46 program.

Based on stockpile stewardship efforts today, we can confidently assert that our stockpile is safe, secure and effective. However, the warheads, on the average, you're talking about being at least on the average 27 years. And life extension programs are needed to mitigate age-related effects and incorporate modern safety and security features.

We must keep the 3+2 warhead strategy moving forward. The failure to carrying out planned infrastructure modernization-like extension programs will increase risk to the long-term safety, security and effectiveness of an aging nuclear stockpile. Even with the efforts we have today, we continue to get older before we get younger.

Maintaining the physical security of our nuclear weapons is important in ensuring a safe, secure and effective nuclear deterrent. Work continues through the services and the intelligence community and Department of Energy to assess threats and determine the most effective vulnerability mitigation measures. And both the Navy and the Air Force continue to carefully scrutinize and improve security measures.

Finally, the strategic deterrent is of course underwritten by effective nuclear command and control and communications. National guidance mandates assured, unbroken, redundant, secure and survivable communication paths between the President of the

United States, his senior advisers, all the way down to the operating forces. We must continue to sustain our current NC3 infrastructure, but in the coming decades further investment will be needed to field modern technology and associated procedures to improve the quality, timeliness and availability and diversity of information provided to senior leaders in the course of the nuclear decision making process.

And, of course, all of the sustainment and modernization efforts I just described require funding. So my third and final point addresses the fiscal environment. Today I have confidence in our ability to operate a safe, secure and effective nuclear deterrent force.

The Navy has sustained investment, currently for the Ohio replacement program. The Air Force still is working to sustain investment in the air leg and intercontinental ballistic missile leg. And we continue to work with the Department of Energy on the right investments for the nuclear stockpile sustainment efforts, which include ongoing life extension programs.

Our predecessors certainly made wise decisions and investments, and we continue to reap those benefits today. But we must not take that for granted. Today's budgetary environment remains a concern as we look to sustain and modernize our military forces, and especially our strategic deterrent capability.

In conclusion, in a world where our traditional adversaries are modernizing, emerging adversaries are maturing, and non-state actors remain elusive and dangerous, we must get 21st century deterrence right. The reality is that an effective and modernized nuclear deterrent force is needed now more than ever. And we must view today's threats in an innovative manner to ensure strategic stability.

My final thought is that the future inherently creates significant uncertainty and will put a squeeze on both our readiness and, of course, our exceptionally talented people who execute our deterrence and assurance mission 24/7. We owe it to them and our nation to get it right. As stated in the June 2013 Department of Defense report on Nuclear Employment Strategy, quote, "The United States will maintain a credible nuclear deterrent capable of

convincing any potential adversary that the adverse consequences of attacking the United States or our allies and partners far outweigh any potential benefit they may seek to gain from such an attack,” end-quote.

So, ladies and gentlemen, we have much work to do. I’m glad to have you on our team and I thank you for your time today. I look forward to the work ahead and appreciate what all of you do for a grateful nation.

MR. SYDNEY FREEDBERG: Sydney Freedberg with Breaking-Defense.com. Coming out of AFA this week and the Air Force because earlier there is a lot of discussion about the Long Range Strike Bomber. It’s not going to be immediately nuclear certified, unlike the other, the ICBM it’s not a dedicated single-mission platform. So how do you make sure that your perspective, your mission, is represented in that program? –And, why is a good old-fashioned bomber so critical to the nation in an age of ballistic missiles and long-range weapons when everything should be done sort of push button.

ADM. HANEY: Sydney, I thank you for that question. If you didn’t hear it, it was really—I’m not sure I’ll get it exactly in the words he just said, but if you look at the Long-Range Strike Bomber and the initial work that’s ongoing to get it down-range and to add the nuclear capability later on in the plan, is that the right thing to do? And, of course, the relevancy of our bombers today that I already said is over 50 years old. The last one went off the assembly line in 1962. Of course, I don’t consider 62 too old, being that I was born before then.

But seriously, first and foremost, the contribution that the air leg makes to our strategic deterrent cannot be undersold. And it’s a very important area in terms of flexible deterrence that our country needs in terms of things. And to have a relevant air leg you’ve got to have the capability to have—as we used to mention for the B-2—a kind of stealth bomber capability and the ability to carry both conventional and nuclear payloads, but the nuclear being in terms

of bombs, and B-52 bombers that can have standoff and use an air-launched cruise missile kind of capability.

As we look at the world and as it gets far more complicated, capabilities—as we look at what is sometimes termed anti-access area denial, it's very important to be able to have a standoff capability. And this business of moving forward with the replacement for the air-launched cruise missile, the Long-Range Strike Option, is just as important as also having a future bomber to be able to work in this complex environment that I described earlier in my remarks. So trying to get at your question as I understand it, number one, the importance of the air leg as we go forward.

The good news is that we have this flexibility with our air leg of conventional and nuclear strategic kinds of payloads. And that piece is very important, as I said, in addressing and ensuring through deterrence that no one would want to take us on in those type of extreme circumstances. So it's not about just pushing buttons.

Thank you very much.



ANNUAL DETERRENCE SYMPOSIUM

**REMARKS BY
MS. ROSE GOTTEMOELLER
UNDER SECRETARY FOR ARMS CONTROL
AND INTERNATIONAL SECURITY
U.S. STRATEGIC COMMAND OMAHA, NEBRASKA**

AUGUST 14, 2014

Thank you for that kind introduction. I am always honored to be a speaker here at the Annual Deterrence Symposium and of course, I am glad to be here at the invitation of Admiral Cecil Haney. Turn about is fair play: The Admiral gave a great speech at my invitation last month in Washington to a group of young people on the threshold of their careers. Thank you, Admiral, for all you do for this nation.

While we are gathered here today in Omaha, the world is facing serious challenges: The threats to Ukraine's sovereignty and Russia's flagrant disregard for international law, the continuing conflicts in the Middle East, a dangerous Ebola outbreak in West Africa. It goes without saying that most people are not focused on nuclear weapons or nuclear deterrence. But we all know that we have important work to do and we do it. My admiration for this community, in and out of uniform, knows no bounds. We are ready to work. That is the theme I'm striking today: We who focus on the foundation of our nation's nuclear deterrent are ready to work.

Strategic stability is the cornerstone of American national security, but as all of you know, it is not a static state of being. Threats to strategic stability can surface quickly and it is incumbent upon all of us to recognize those threats, anticipate them when we can, and make moves to counter them. We must be prepared for the unpredictable, and constantly on the look-out so that we see threats emerging while they are still over the horizon.

My role as a diplomat is different from your roles on the military side, but our goals are no different. As President Obama said five years ago in Prague, as long as nuclear weapons exist, we will maintain a safe, secure, and effective nuclear arsenal. And that is as we seek the peace and security of a world without nuclear weapons.

Violation of the Intermediate Nuclear Forces Treaty (INF)

One threat to strategic stability has made news in the last month. As you all know, the Department of State recently delivered the Annual Arms Control Compliance Report to Congress with the determination that the Russian Federation is in violation of its INF Treaty obligations not to possess, produce, or flight-test a ground-launched cruise missile with a range capability of 500 to 5,500 kilometers, or to possess or produce launchers of such missiles.

We have been attempting to address this very serious matter with Russia for some time, as the United States is wholly committed to the continued viability of the INF Treaty. We are asking Russia to return to compliance with the Treaty in a verifiable manner. This groundbreaking treaty serves the mutual security interests of the parties – not only the United States and Russia, but also the 11 other states bound by its obligations. Moreover, this Treaty contributes to the security of our allies and to regional security in Europe and in the Far East.

When we notified Russia of our determination of a violation, we made it clear that we are prepared to discuss this in a senior-level bilateral dialogue immediately. We hope that this dialogue begins soon, with the goal that Russia return to compliance with its obligations under the Treaty. There is an expert debate in Russia about its nuclear modernization programs and about the contribution of the INF Treaty to Russia's security. It is important for Russia to take into account that no military decisions happen in a vacuum. Actions beget actions. Our countries have been down the road of needless, costly and destabilizing arms races. We know where that road leads and we are fortunate that our past leaders had the wisdom and strength to turn us in a new direction. Let us

hope that debate in and out of the government leads to a decision to return Russia to compliance with all of its international obligations.

New START and Future Reductions

Despite our serious concerns about Russia's violation of the INF Treaty, we believe that the New START Treaty is in the national security interest of the United States. The New START Treaty enhances our national security and strategic stability with Russia and both the United States and Russia are implementing the Treaty's inspection regime. Current tensions with Russia highlight the importance of both the verification and confidence provided by data exchanges and on-site inspections under the Treaty, and the security and predictability provided by verifiable mutual limits on strategic weapons. We take questions about compliance with arms control treaties very seriously and are closely monitoring Russian compliance with the New START Treaty. We assess that Russia is implementing and complying with the New START Treaty, and that the Treaty remains in our national security interest. The mutual predictability this gives to the U.S. – Russia relationship increases stability, especially during difficult times such as now.

With respect to future agreements, the United States will only pursue agreements that are in our national security interest and that of our allies. The offer that President Obama made in Berlin one year ago, of an up to one-third reduction in operationally deployed warheads beyond the New START limits, is a sound one, and worthy of serious consideration. We will continue to be open to discussion of agreements that would reduce nuclear and other military threats. Of course, we know that the situation is different than it was four years ago, four months ago, four weeks ago. But cooperation in the arms control realm has been an important facet of strategic stability over the past forty years and it should remain so in the future.

Moreover, we need nuclear cooperation with Russia and others to address new threats, first and foremost the risk that terrorists could acquire a nuclear weapon or the fissile materials needed to make one. We will continue to pursue arms control and

nonproliferation tools, because they are the best—and quite frankly—the only path that we can take to effectively prevent a terrorist nuclear threat and reduce nuclear dangers more broadly.

The United States has taken steps to reduce the role of nuclear weapons in our national security strategy. We have clearly stated that it is in the U.S. interest, and that of all other nations, that the nearly 70-year record of non-use of nuclear weapons be extended forever. We are taking time now to prepare the ground for the future. That includes more research into how we incorporate new technologies and innovations into verification and monitoring. We can also shape, maintain, and improve strategic stability through a variety of bilateral and multilateral dialogues, including in the Track 1.5 and Track 2 realms. These engagements reduce the potential for misunderstanding and provide the basis for future agreement and cooperation.

Multilateral agreements like a Fissile Material Cutoff Treaty (FMCT) can also enhance global stability. The United States will continue to push for the commencement of negotiations on such an agreement. And we are working to expand our public outreach and educational efforts on the Comprehensive Nuclear Test-Ban Treaty. As stated in the April 2010 U.S. Nuclear Posture Review: “Ratification of the CTBT is central to leading other nuclear weapons states toward a world of diminished reliance on nuclear weapons, reduced nuclear competition, and eventual nuclear disarmament.” As we consider arms control and nonproliferation priorities, we will continue to consult closely with our allies and partners every step of the way. Our security and defense – and theirs – is non-negotiable.

Conventional Deterrence Tools

While nuclear deterrence is and will remain an important part of protecting our nation and our allies, we must also make full use of our non-nuclear capabilities—that includes regional and homeland missile defenses, security cooperation, assurances and conventional arms control. Of course, the Russian Federation’s challenge to the security of Europe and Ukraine’s territorial integrity has to be factored into our work to modernize conven-

tional arms control. First and foremost, we need to make the best use of the regimes currently in place. The Vienna Document 2011 and the Open Skies Treaty, which are part of the conventional arms control regime in Europe, are vital tools to maintain stability and have provided transparency about military activities in and around Ukraine.

Second, we must consider our options for the future. We will continue the process of modernizing the Open Skies Treaty, including the upgrade to digital sensors to replace obsolescent film cameras. With regard to the Vienna Document mechanisms, it is clear to us that there is room to improve provisions for notification of military activity and risk reduction, among other issues. Moving forward, the United States will work with others to update the Vienna Document in a way that builds on our recent experiences. NATO will also continue its review of the future of conventional arms control in Europe. We recognize that now is not the time to engage Russia on this, but we need to be thinking now about how in the future a revitalization of conventional arms control in Europe could contribute to improving mutual security in the Euro-Atlantic region.

Of course, we are not without good examples to follow. We can and will benefit from the experience of the so-called Dayton Article IV states. Eighteen years ago, these states in the Western Balkans were emerging from years of bloody conflict. Through hard work, they established military stability and security, despite a range of differences. The architects of Dayton created a comprehensive arms control agreement that led to significant reductions in heavy weapons and equipment in just six months. Without as much as a breather, the states involved then turned their efforts to the harder step of fulfilling the obligations laid out in the Agreement, to sustain disengagement of military forces and create a stable security environment for all. The Dayton Article IV experience is a testament to what can be achieved through conventional arms control measures at a time when they are being sorely tested elsewhere in Europe.

Space and Cyber Deterrence

In addition to fully realizing the potential of conventional deterrence, we must make sure that we are ahead of the curve on space and cyber issues. I know this was the subject of a panel yesterday and rightly so - it is critical that we identify ways to stabilize behavior in both realms. My colleague, Deputy Assistant Secretary Frank Rose spoke about strategic stability in space yesterday, highlighting the point that it is essential that all nations work together to adopt approaches for responsible activity in space in order to preserve this domain for future generations. China's recent irresponsible and provocative ASAT test accentuates the importance of these efforts. Russia's pursuit of anti-satellite weapons is also a matter of concern. Destabilizing actions like these threaten the long-term security and sustainability of the outer space environment. In the cyber realm, the Department of State's Office of the Coordinator for Cyber Issues, led by Chris Painter, is leading our efforts to promote an open, secure, and reliable information and communications infrastructure that supports international trade and innovation, strengthens international security, and fosters free expression. As we move forward, we should continue to cooperate and coordinate both internally and with our friends and allies. Such efforts as the UN Group of Government Experts that convened last month will continue to enhance our common understanding of the ways in which international law is essential to maintaining peace and stability in cyberspace. Cyberspace can be the source of both great societal advances and significant threats. There is no doubt that domain will only remain stable through our collective efforts.

Deterrence in the Future

Of course, you know all of this—all of what we have been talking about—is moot if we don't attract the next generation to nuclear policy jobs. As I said at the outset, this community is ready to work, but we can't work forever. We have some recruiting to do. Frank Klotz struck this same note this morning: we need to bring the next generation into the nuclear deterrence enterprise. That is why I was so pleased that Admiral Haney was

able to join the Department of State's 5th Annual Generation Prague Conference that was focused on engagement with the next generation of nuclear experts. It is one piece of ongoing efforts, but it is not enough. We need to be actively recruiting political scientists, lawyers, physicists, geologists, engineers, and more, if we want to make sure that this essential part of national security will be supported as long as it needs to be.

In closing, I want to leave you with a thought. History has shown us that when faced with obstacles, we always have several paths. When it comes to our current situation with the Russian Federation, I, for one, want to follow the path that President Reagan took, the path that President George H.W. Bush took. When confronted with a difficult and sometimes unpredictable partner in the Soviet Union, they did not take their ball and go home. They did not let strategic stability become a political punching bag. They set about the hard task of building up strategic stability through arms control treaties and agreements, and they succeeded in making this world a safer place. They worked hard, and achieved much. So let's leave Omaha ready to work. In the world of nuclear stability and deterrence, there is much to do.

Thank you.

**MINOT TASK FORCE 21 CONFERENCE ON
“THE STRATEGIC NUCLEAR ENTERPRISE:
IMPLEMENTING THE ROADMAP AHEAD”**

**RDML JOE TOFALO, USN
DIRECTOR, UNDERSEA WARFARE (N97)**

SEPTEMBER 18, 2014

Peter, thank you for the kind introduction, and my thanks to Task Force 21 for this opportunity to be with you today. I'd also like to wish a happy birthday to all U.S. Air Force service members here today, past and present, as the Air Force was founded 67 years ago.

I'm RDML Joe Tofalo, Director of Undersea Warfare on the Navy staff in the Pentagon, OPNAV N97.

I took the job about 10 months ago, having come from command of Submarine Group 10 in Kings Bay, GA, where I was responsible for all Atlantic SSBNs and SSGNs. In my current job as N97, I'm both the head Requirements Officer and Resource Sponsor for the U.S. Submarine Force, to include requirements and resourcing the OHIO Replacement program. So between my most recent and present assignments, I am fortunate to have both operational and Echelon I headquarters perspective on the Sea Based Strategic Deterrent. To be clear, the Sea-Based Strategic Deterrent is my, and the Navy's, #1 priority. It is also clear that it is a high priority for many in Congress, and Senator Hoeven's words on OHIO Replacement this morning are greatly appreciated.

There is one key message I want to make sure everyone takes away today. For the foreseeable future, and certainly for our and our children's lifetimes, the United States will require a safe, secure and effective strategic nuclear deterrent, and the SSBN force will be a critical part of that deterrent.

Why am I so sure of this? Let me walk you through four points of my reasoning.



First, there is every indication that strategic nuclear deterrence will become more challenging – not less challenging – in the future. Let me give you some examples:

The President has made clear that the United States will maintain a safe, secure and effective nuclear deterrent as long as nuclear weapons exist. Both Russia and China have recently indicated that they intend to strengthen, not weaken, their nuclear forces. North Korea clearly depends on nuclear forces to extort the international community. Iran is enduring substantial international sanction pressure in order to continue its nuclear program. Taken together, the various nuclear states have articulated any number of strong reasons to maintain and in some cases increase their nuclear force capabilities.

During the recent Nuclear Security Summit attended by 58 world leaders at the end of March, 35 countries pledged to turn international guidelines on nuclear security into national laws, and open up their procedures for protecting nuclear installations to independent scrutiny. Notably absent from the agreement were Russia, China, India, Pakistan, North Korea and Iran—the six countries that we most focus on when we think about our own deterrent effectiveness.

Both Russia and China have made clear that they are modernizing their nuclear forces and increasing their reliance and emphasis on nuclear weapons. Both countries have a new SSBN in the water and are testing a new sea-based ballistic missile—we do not.

Clearly, the strategic deterrence environment is going to be more challenging in the future.

Now, point #2: Maintaining an effective strategic deterrent in the face of these challenges will continue to require a Triad, of which SSBNs by virtue of their survivability are an essential part. It is the Navy's stated position that the Nation should retain its nuclear Triad. Each of the Triad's legs brings unique strengths that provide a strong deterrent against different classes of adversary threat, and each of the legs reinforces the effectiveness of the others.

For the SSBN force, the unique strength is survivability. The

SSBN force provides the President with an assured ability to robustly respond that is capable of deterring both attack and coercion through the threat of attack.

A common misconception is that the number of warheads is the main driver for how many SSBNs we need.

The SSBN force is sized to keep the right number of platforms in the right place and in the right posture all the time. Geography, survivability and target coverage are in fact the primary drivers in sizing the force—not the total number of warheads.

The ability to adapt to emerging threats also plays a role. For instance, as we are selecting requirements for the Ohio Replacement SSBN, we have to ensure that its stealth paces the projected threat. We do this by carefully looking at the evolution of proven technologies, the emergence of credible threats, and detailed analysis of all available intelligence.

In order to provide a survivable assured response, our SSBNs must provide our adversaries with an insurmountable problem. We do this by ensuring we have multiple stealthy platforms distributed across large ocean areas in both the Atlantic and the Pacific. Our goal is to effectively remove the incentive for an adversary to even attempt to locate our at-sea SSBNs.

To put things in perspective, SSBNs have over half of the Nation's deployed nuclear warheads. Their survivability is essential if our deterrent is to remain robust and credible.

So, maintaining a robust survivable SSBN force is critical, but how can we do this in the most affordable way?

My third point is that by leveraging a variety of tools, the Navy provides SSBNs to the Nation in the most cost effective manner possible.

Let's go through some of the ways the Navy has controlled the cost of the SSBN force:

First and most importantly, we have delayed recapitalization of the SSBN force for as long as possible. We built 18 OHIO SSBNs and designed them for a 30-year service life. If we had replaced them on the original schedule, we would have needed the first replacement SSBN at-sea in 2011—three years ago. In fact, tomorrow, we are celebrating the 4000th strategic nuclear

deterrent patrol by our SSBN force; ADM Haney will be speaking in Kings Bay to commemorate it. The timing of the celebration happens to coincide within a month of when we should have been decommissioning the first of the remaining OHIO SSBN (USS Henry M. Jackson—originally scheduled for decommissioning on 06 OCT 2014). Instead, the first OHIO Replacement SSBN won't go on patrol until 2031—a full twenty years after the original 2011 patrol date.

How did we do this? We reduced the SSBN force at the end of the Cold War from 18 to 14. That bought us four years. Then, after extensive engineering analysis determined it was acceptable, we extended the service life of each ship by 12 years—now we're at 16. Then we incorporated design changes into the OHIO Replacement SSBN so that 12 could do the work of 14 OHIOs, gaining us two more years of delay—now we're at 18 years. Finally, we accepted the risk of an additional two-year delay, which will also have us transition from OHIO to OHIO Replacement at a force level of only ten ships. You heard what Congressman Rogers had to say about that this morning. All combined, that's 20 years later than originally planned—there is absolutely no room for more.

This ten-ship force is acceptable during the transition period only because none of our SSBNs will be in overhaul during that period. The OHIO Replacement force will ultimately build up to a force of 12 ships. The last two enable us to do the necessary overhaul work on the others near the middle of their service life without dropping below the minimum operational force level of ten ships.

I have taken the time to walk you through the 20-year sequence because it has literally saved the nation billions of dollars and, separately, it has delayed the expenditure as well. Just cutting two SSBNs off of the required force size saved us more than \$20B in procurement and operating costs over the life of the class.

Making the force lean like this saves money, but it applies pressure to the force that cannot be ignored. This increases our level of risk.

The OHIO Replacement is being designed with cost-efficiency

in mind. We're going from 24 missile tubes in OHIO to only 16 tubes on the OHIO Replacement. We are incorporating components already in use in the VIRGINIA-class attack submarines, letting us save money on design, on training pipelines, and on logistics support.

We no longer design custom electronics for each submarine. We stopped doing that years ago to leverage the cost-savings that come with Commercial Off the Shelf technologies. As a result, the OHIO Replacement will have common sonar, fire control, and radio systems along with the other submarines in the fleet, again saving us maintenance, training and logistics costs.

One of the main reasons we can use 12 OHIO Replacements to do the work of the 14 OHIO SSBNs is because the new SSBNs will start with a 42-year service life and will not need to be refueled or extended. This will reduce the duration of the mid-life overhaul, making 12 ships sufficient.

In addition, we have taken advantage of our long-standing relationship with the United Kingdom to share the development cost of our OHIO Replacement with their Successor-class SSBN. This has led to our mutual development of a common missile compartment, creating savings for both nations.

We have been operating SSBNs for over 55 years. With each new design we incorporate lessons and efficiencies learned from our operating experience with the earlier ships. By leveraging both our long operational experience and the tremendous cost-control techniques we have learned with the VIRGINIA-class SSN, we have been able to ensure that the OHIO Replacement is as affordable as possible while still having the capabilities it must have to be viable into the 2080s. Let me emphasize that date... the 2080s... that's a long time with a lot at stake. We've got to get this right.

Recapitalizing SSBNs only happens every other generation. We've already extended the OHIO from 30 to 42 years and it's now this generation's turn to recapitalize the sea-based strategic fleet. The unfortunate thing about SSBNs is that we have historically procured them in tight groups, ever since the first 41 SSBNs were procured in just 7 years (repeat, 7 years). This means

that they must be replaced in tight groups as well. The OHIO SSBNs were procured at a rate of one per year, so that means we must procure its replacement at one per year if we are going to meet our strategic operational requirements.

We have delayed OHIO Replacement as long as possible, and 2021 is the latest we can start construction and execute the first deterrent patrol by 2031 with no gap in the required strategic presence.

Even when done in the most cost effective manner, the recapitalization of the SSBN force at about one per year requires the commitment of significant national resources for about 15 years. This creates a challenge for the Navy shipbuilding program.

So this brings me to my fourth and final point. We must take steps to minimize the impact that OHIO Replacement procurement has upon the rest of the shipbuilding plan.

The Navy shipbuilding plan emphasizes stable procurement lines in order to maximize cost-efficiency. If the Navy alone were to absorb the entire cost of the OHIO Replacement SSBN within the existing ship construction budget, it would consume at least one third of the available money. Over the course of the 12 years associated with those 12 OHIO Replacements, that's like losing four years of ship procurement money. That means that all of the other shipbuilding programs would be disrupted by a third to make up the difference.

This would make the other disrupted production line less efficient and increase the cost of each of these platforms, and result in overall fewer Navy ships. Given that the Navy is already stressed with the force levels today, there is no room to absorb this kind of ship construction impact. Add the realities of Russian and Chinese aggressiveness, and the problem becomes even more acute. The bottom line is, as referred to in the 30 Year Shipbuilding Plan, the Navy cannot procure OHIO Replacement in the 2020s within historical funding levels without severely impacting other Navy programs.

We do need to pause for a minute to ensure we all understand the phrase "historical Navy shipbuilding funding levels," as it is often quoted in the press. When it is used, perhaps the caveat

recent should be added to historical, as often only the last twenty years are what is being considered. We must remember that the last 20+ years do not include the procurement of SSBNs—we procured our last SSBN in 1991. When we do buy the OHIO Replacement, it will have been 45+ years since the procurement of the first OHIO. So it does not make sense to hold the shipbuilding accounts constant when “recent” averages, or “recent historical funding levels,” did not have to account for building SSBNs. The Center for Naval Analyses did a study that determined that the Navy’s annual shipbuilding account has been about 5 to 6 billion dollars higher in the years that we procured SSBNs—including the ‘41 for Freedom’ and the OHIO Class. This historical analysis, which looks at the full historical perspective and not just the last 20+ years, is consistent with what we see is needed today.

So, yes we will have to bear the burden of paying for these SSBNs during the 2020s, but they will remain in service into the 2080s, and they come with all of the fuel they will ever need. Given the significant magnitude of their mission (preventing major power war), the infrequency of their procurement burden (every other generation), the need to not impact the rest of Navy shipbuilding, and their outstanding amortized value (into the 2080s), the case for top line relief is very strong.

Top line relief can come in one of at least two ways. Either via the shipbuilding account, as the Center for Naval Analyses study I previously mentioned indicates has been done if you look at the full history, or via a properly funded separate account outside the Navy shipbuilding account. As Mr. Stackley, the Assistant Secretary of the Navy for Research Development and Acquisition, testified to the House Armed Services Committee in early July, such a fund is just a *vehicle*. So what really matters is additional resources regardless of the vehicle. Secretary of the Navy Ray Mabus just reiterated this point earlier this week in his remarks at the Council on Foreign Relations. Again, either approach is acceptable, but for the Navy to take OHIO Replacement *out of hide* from within current projected shipbuilding account limits just doesn’t make sense.

So where does this leave us?



The Cold War may be in the past, but the world that is ahead of us is even more complex and challenging. There is much work to be done to address problems like North Korea, Iran, a resurgent Russia and an emerging China.

There will undoubtedly be other problems that will arise that are not even on our radar scopes today.

We will need a strong deterrent, and it will need the flexibility of the bomber leg, the responsiveness of the ICBM leg, and the survivability of the SSBN leg. We have saved the country literally billions of dollars by deferring and shrinking our nuclear forces to the limits of what is reasonable. We are at the point now where <0.7% of federal outlays go to nuclear deterrence and the prevention of major power war. This is a tremendous return on investment, but it can go no lower.

Now is the time to recapitalize the SSBN force. There is no further room for delay or force reduction. We must ensure that we properly fund the development and building of the OHIO Replacement, and continue to leverage all of the tools we can to make it as affordable as possible. And this affordability extends beyond *cost*. We also have to make sure that we can afford the impact on the size of the rest of the Navy.

Thank you to everyone in the audience who makes today's nuclear deterrent safe, secure and effective. Holding that standard in the future is a tall order, but we must and will make it happen.

**AIR FORCE ASSOCIATION,
NATIONAL DEFENSE INDUSTRIAL ASSOCIATION, AND
RESERVE OFFICERS ASSOCIATION FORUM WITH
DR. KEITH PAYNE,
PRESIDENT OF THE NATIONAL INSTITUTE
FOR PUBLIC POLICY;
AND AMBASSADOR ROBERT JOSEPH,
SENIOR SCHOLAR AT THE NATIONAL INSTITUTE
FOR PUBLIC POLICY, ON “NUCLEAR FORCE
ADAPTIBILITY FOR DETERRENCE AND ASSURANCE:
A PRUDENT ALTERNATIVE TO MINIMUM
DETERRENCE”**

Editor’s Note: The business end of Nuclear Deterrence, the airmen, missilemen and sailors who work hard every day at the readiness required, know what Nuclear Deterrence means to them. There are others, however, who have a very different concept of what is necessary and their arguments are heard frequently and in high places. Their’s is a concept of Minimum Deterrence to put that concept in context the author states here:

“Minimum Deterrence is reflected in the many, many proposals that have been around since the ‘50s that suggest that U.S. force posture adequacy can be defined by anywhere from several nuclear weapons to up to about 1,000—several to up to about 1,000....

Minimum Deterrence puts a very tight box around the types of forces the United States should have. They shouldn’t be numerous, they shouldn’t be counterforce, they shouldn’t provide damage limitation capability, they shouldn’t look like they’re for war fighting purposes; and they should be effective at retaliating against societal targets. So that’s essentially what Minimum Deterrence is.”



MR. PETER HUESSY: This is the first presentation on a new publication that Keith and NIPP have done which has chapters from people such as General C. Robert Kehler, USAF, Ret. and ADM Richard Mies, USN, Ret. and others.

Today we're very privileged to have Keith Payne and Ambassador Bob Joseph, who is coming from an Emmy award-winning presentation before the House Armed Services Committee yesterday.

Keith, as you know, is President of NIPP, formerly in the Department of Defense. Bob, as you know, was a top arms control, counter-proliferation expert in the Department of State, was at the White House. I still think Bob is kind of the inventor of the Proliferation Security Initiative, and one of the great accomplishments, of course, was the ending of the nuclear program in Libya.

They're going to talk about basically their new report that looks at if we don't do minimal deterrence, what should we do? And they're going to go through that and it is on the record. I will be getting a transcript and making that available to you.

I want to thank our sponsors. I want to thank our Air Force colleagues for being here. In particular, I want to thank Jeff and Tom Colin, both of whom helped put this together on short notice. We're going to first hear from Keith, and then Bob.

Would you give a warm welcome to Dr. Keith Payne?

DR. KEITH PAYNE: Thank you, it's great to be here this morning. Thanks to Peter, who does such a great job with these events. My appreciation to Peter for all that effort.

What I'd like to introduce this morning is a new study that literally is just out today. This is the draft copy that we have of it, essentially the galley copy. And apparently the first shipment of the publication will arrive today.

This new study is a sequel to this 2013 report. This is the study that came out in 2013, the title of which was, *Minimum Deterrence: Examining the Evidence*. The new 2014 study is entitled, *Nuclear Force Adaptability for Deterrence and Assurance: A Prudent Alternative to Minimum Deterrence*.

The contributors to each of these studies are important because in this town what is said is important, but also who is behind the saying of it is very important. So I'll just mention the contributors. The senior review group for the first study, the 2013 study, included the late Dr. Jim Schlesinger, who was the head of the senior review group. The senior review group included folks who many of you know, some of you worked with, I'm sure: Gen. Don Alston, Gen. Roger Burg, Gen. Kevin Chilton, Ambassador Courtney, Ambassador Edelman, Dr. John Foster, Prof. Colin Gray, Ambassador Joseph, Admiral Mies, the Honorable Frank Miller, Senator Charles Robb, Dr. Bill Schneider, General Welch and the Honorable Jim Woolsey.

That was the group that was behind the first study. And the study was endorsed by Senator Kyl and Senator Lieberman. So what we had was a very bipartisan group that included civilians, retired military, technical folks, spelling majors, the whole gamut.

The second 2014 report, the sequel that has just come out, has a very similar group of folks who have contributed to it, although we added to that in a couple of ways. We added General Robert Kehler, who just came off of being commander of STRATCOM, as you all know. In addition, we invited Dr. John Harvey, recently out of the Obama administration at DOD, and Dr. Brad Roberts, also recently out of the Obama administration at DOD. So what we've tried to do is put together again a continuing group, very bipartisan, having a diversity of folks involved.

Let me go through briefly what the goal was of these two studies taken together, because in some ways they really need to be taken together. The first 2013 publication, as I said, the title is *Minimum Deterrence: Examining the Evidence*, was to hold up Minimum Deterrence to a critique of: what does evidence tell us about its claims? Never-mind the usual narrative of theory, but what does evidence actually tell us?

And when I say Minimum Deterrence, bear in mind what I'm referring to. I'll do it in shorthand. Minimum Deterrence is reflected in the many, many proposals that have been around since the '50s that suggest that U.S. force posture adequacy can be defined by anywhere from several nuclear weapons to up to about

1,000—several to up to about 1,000. And the sole purpose of U.S. nuclear weapons should be to deter other nuclear weapons; the United States should have a very constrained type of force posture in that the nuclear forces should be designed largely to target large soft areas. This goes back to McNamara's urban industrial targeting. In other words, counterforce is not a good and defensive capabilities, whether offensive or defensive, are not a good idea for a couple of reasons.

Minimum Deterrence puts a very tight box around the types of forces the United States should have. They shouldn't be numerous, they shouldn't be counterforce, they shouldn't provide damage limitation capability, they shouldn't look like they're for war fighting purposes; and they should be effective at retaliating against societal targets. So that's essentially what Minimum Deterrence is. And the numbers, as I said, depending on the proposals you read, range from several—literally several nuclear weapons are adequate for the U.S. force posture, up to about 1,000. Depending on which proposal you read, you'll see the numbers in there are somewhere—100 is a frequent number, 500 is a frequent number, but they range from several up to about 1,000.

As I said, the goal of the 2013 study was to assess this Minimum Deterrence narrative against actual evidence and logic. The conclusions that we came to, that this group came to, was that by and large the Minimum Deterrence narrative is contrary to evidence that is available with regard to how you might put together a methodology for force sizing. It's contrary to evidence and it has internal logical problems. In other words, it's self-contradictory in many ways. Other than that, it's a brilliant piece of work.

So that was the conclusion of the first study. Many of you have it. If you don't, let us know and we can make sure we get you a copy, or Peter can make sure you get a copy.

We started working on the 2014 study while this one was being briefed. What we wanted to do with this sequel was address the question: if not Minimum Deterrence then what? It's not enough just to drive a stake through the heart of Minimum

Deterrence—an approach that has zombie-like resilience. It comes back every decade, sometimes by a different cast of characters, sometimes by the same cast of characters that was presenting it in the ‘60s. It’s not enough just to put a stake through the heart of Minimum Deterrence, we need to provide an alternative. So the study coming out today is subtitled, “A Prudent Alternative to Minimum Deterrence.”

And so let me suggest just two things, and I’m not going to take much more time here. The first is, why do this? And, why go about this?

As far as I can see there is nothing comparable to these two studies. If it exists somewhere, it exists in great secrecy. I can’t find anything that actually does this work anywhere, including my old, old dusty archives of work at Hudson Institute work.

I thought if somebody has done this work before, it must have been the late, great Herman Kahn. But, I couldn’t find it. It’s amazing, given the longevity and the political salience of Minimum Deterrence, that no one, as far as I can tell, has subjected it systematically to the light of evidence.

My colleagues and I decided to fill this gap in the debate. So the question is, Why do it now?

I think the answer is because in many, perhaps most quarters in this town, the Minimum Deterrence narrative, just as I described it, dominates thinking. It dominates what is thought to be a post-Cold War thinker; in fact, the mocking criticism of anything that’s outside of the Minimum Deterrence narrative is that it is Cold War thinking. So what we wanted to do was take a close look at this powerful narrative with regard to U.S. strategic weapons, nuclear weapons and policy and arms control.

I think it’s fair to say that Minimum Deterrence has been increasingly powerful for about the last two decades. Despite the best efforts of a relatively small group of people, some of whom are in this room right now, this particular approach to thinking about nuclear force policies is winning the competition of ideas. In fact, I’m always surprised that people are surprised when developments that are consistent with Minimum Deterrence emerge. In each case, the question is, how did that happen?

What's a reflection of this? Well, RNEP gets killed. How did that happen? Prompt global strike gets killed or downplayed. How did that happen? RRW gets killed. How did that happen? The future of the triad is extremely questionable. How does that happen? We give up TLAM-N unilaterally. How did that happen? We put enormous limits on missile defense even though the ABM Treaty is gone. How does that happen?

We have popular Minimum Deterrence proposals for declaratory policies that are ridiculous. For example, the *sole purpose* declaratory policy is a ridiculous declaratory policy. How does that happen? What it says is that U.S. nuclear weapons are only useful for deterring nuclear weapons, and that's how we should plan.

But, what about biological weapons? What about chemical weapons? Do we deter those threats with fairy dust? *Sole purpose* sounds so nice, so balanced. But, it corresponds to acquisition policies that are equally ridiculous in the current environment. For example, the current policy of *No new capabilities*. Really? No new capabilities? What does that come from? We have no idea what the threats are going to be two years from now, five years from now, 10 years from now. Nevertheless, we're going to stay with legacy nuclear capabilities from the '60s and '70s for deterrence essentially forevermore, because somehow we know that those are the capabilities that will be necessary to deter enemies and assure allies 10 years from now?

That's an unthinking point of view. It says that you can predict the future and you know that what you've got now is just right. But, no one can predict that. You'd have to be omniscient to know that, but that's U.S. policy. These are all reflections of Minimum Deterrence.

What about arms control policy, the New START Treaty, the recent administration proposal for deeper U.S. reductions down to 1,000, and then down ultimately to nuclear zero? This overarching drive to even-lower numbers is a reflection of the Minimum Deterrence narrative. When they happen individually in history we ask where did that come from? But, if you put them together, you know why they happened: they happened because the strategic

debate in this country is dominated by the Minimum Deterrence narrative. If you get outside of it, you're basically dismissed as a Cold War thinker by many.

So what we wanted to do in the first study was take a serious look at Minimum Deterrence and examine it in light of evidence and logic. And once you get beyond that, once you establish that it has problems with evidence and logic, where do you go next? That's what we did with this new study, take a look at what policy direction actually is consistent with evidence, what actually has internal coherent logic.

We started out asking, "what are the U.S. priority goals?" The answer is, assuring allies and deterring enemies. What does the strategic environment look like in which we must pursue those goals and where does it look like it's going? What characteristics does that tell you should be important to our force posture? And then the next step is, what does that tell us should actually be the nature of our forces, the nature of our arms control policy, the nature of our declaratory policy? That is the structure of this new study.

Let me tell you that the conclusions we reached do not look like Minimum Deterrence. Now, let me get off the stage here and turn it over to Ambassador Joseph.

Ambassador Joseph, I believe, is going to talk about where we ended up with regard to arms control and missile defense. But he'll talk about whatever he'd like to talk about.

AMB. ROBERT JOSEPH: Good morning. Let me also thank Peter and all of the sponsors, Jeff and others. It was a privilege to be part of the study group for both of these studies. I am grateful that I was allowed to participate.

I think Keith has done a terrific job providing an overview of the studies, and particularly of the impact or influence of minimum deterrence on U.S. strategic thinking currently. What I'd like to do is scope down a bit, just take a few minutes and, as Keith said, talk about arms control and missile defense and how they can add to, or in the case of arms control, detract from the



flexibility and resilience of U.S. strategic and theater nuclear forces.

With regard to arms control, it has long been a U.S. objective to limit the adversary's counterforce capabilities. Going back to SALT and then particularly the START days, one of our objectives was to limit and in fact ban heavy ICBMs. We did actually achieve that objective in START II. But unfortunately, as most of you undoubtedly know, that treaty was never ratified by Russia.

But the concept is sound, and that is by limiting the counterforce capabilities of your adversary you enhance the survivability of your own force, providing greater flexibility and greater resilience. Arms control can also contribute to flexibility and resilience by preserving options, preserving options for our own forces. And this is one of the reasons that in the 2002 Moscow Treaty we decided not to have any limit on launchers. It would provide us with more flexibility to deal with an uncertain future.

The NIPP report emphasizes the need to keep our options open in this regard, given Russia's expansion and modernization of both its strategic forces as well as missile defenses, given the lack of transparency associated with Chinese strategic modernization, and of course given the fact that in the future we will be surprised. Strategic surprise is a given for the future. The report also sets out a number of specific arms control do's and don't's to guide policy, and let me just refer to a number of them.

In principle, U.S. arms control policy should help preserve U.S. force survivability across the board by constraining the deployment of the opponent's counterforce capabilities. Arms control should help preserve U.S. flexibility via freedom to mix and correspondingly avoid extensive sub-limits on U.S. systems in any future reductions. Arms control should avoid legally locking in reductions for long periods of time that would constrain the U.S. capacity to adapt to future changes in the threat environment.

Arms control should avoid limitations that would compel U.S. forces to rely for their survivability on practices that work against flexibility, such as launching ICBMs on warning or under attack, or ICBMs that must dash on warning in order to survive, a concept

that was, as you know, explored in the context of MX deployment. Arms control should avoid further cuts in force structure until next-generation missiles and bombers are in production. Without operating facilities, further reductions would take many years to reverse and would limit resilience and flexibility.

And finally, arms control should avoid negotiated limits on non-nuclear capabilities that could particularly undercut adaptability, potentially including limits on ballistic missile defense and conventional capabilities such as prompt global strike. A number of these do's and don'ts were violated in the context of New START, and we can certainly get into that if you like.

Finally on arms control, the report makes clear that policy makers need to be aware of the tradeoffs between U.S. arms control and nonproliferation objectives on the one hand and U.S. deterrent, including U.S. extended deterrence requirements, on the other hand. To put it directly, we need to resist going to very low numbers in the name of nonproliferation when the consequences would be a less flexible and less resilient, and therefore a less credible nuclear posture that could, in fact, lead to more proliferation rather than the stated objective of those who advocate going to very low numbers in the name of nonproliferation.

On missile defense, the report provides a sound basis or launching point to examine how our missile defenses can be used to contribute to the flexibility and resilience of our offensive posture. Missile defense, for example, could provide the president with more options in a crisis. One example, if North Korea is seen assembling a long-range ICBM class missile in a time of heightened crisis, the president may think he has only two options.

One would be to pre-empt, the other would be to risk the destruction of an American city. Missile defense provides the president with more options, with more time, to deal with that crisis. In terms of providing greater resilience for our forces, missile defense through preferential defense of our offensive forces, could help avoid the need to take measures such as launch on warning or launch under attack.

I know we want to get to questions and answers and have an exchange. Let me conclude with characteristically one optimistic

note. And my optimism has to deal with—I'm glad Peter is sitting down—arms control. I think arms control is dead. That's my optimistic point.

I don't believe that there is a chance that we will move forward in the near term with arms control negotiations, despite the hopes of high level office holders currently. I couldn't help but think of the exquisite timing of the QDR. The 2014 QDR came out the same week in which Mr. Putin swallowed Crimea. The QDR emphasizes the need for more negotiations with Russia to reduce further our offensive capabilities.

I don't think that's going to happen. I think Russia has stated that it has no intention of negotiating on theater nuclear forces. Why should they? We have given them an eight or 10 to one advantage in that area. There's nothing in it for them. And clearly, given their modernization and expansion of strategic forces, they have no interest in further limits on these systems.

That said, will they negotiate another agreement like New START that requires us to go down further and allows them to go up further? Yes. But I don't think even that is going to happen. But as Keith said, at some point arms control will arise from the ashes. There is no question.

One thing I've learned in over 30 years in Washington is that a bad idea in this town never goes away. You will see it return. And I think what this report does is provide a sensible guideline for future arms control policy.

With that, we will take questions and comments.

MR. HUESSY: I'd like you both to answer a question about, how does your report reinforce or address the issue of extended deterrence not only for our allies in Europe and NATO, but also in the Far East, particularly in Japan and Taiwan?

DR. PAYNE: Great question. In fact, the report looks at that in some detail, both reports do. The question is, if the assurance of allies is a goal—and it is, what does it take to assure them? Up until a decade or so ago we generally decided that whatever we did ought to assure them, and if they weren't smart enough to figure that out, then they should become smarter.

As I've said on occasion, when I spoke with a senior Japanese leader—had a chance to talk with him with regard to some of these issues, I said, how do you think the United States should go about things to best assure you in Asia? And he said, you know, no one has ever asked us that question before. I don't know if that's true, but that was certainly his impression. Many allies are paying much greater attention at this point.

So the question is, how do you actually assure allies? And the first answer is, by understanding what they see as their vulnerabilities and concerns; and then, asking what can we do to help address those? Again, to be charitable, up until maybe a decade ago we tended to think as long as we met our own deterrence requirements, allies ought to be assured.

Let me just suggest that assurance requirements sometimes can be extremely different from how we define deterrence requirements. The Healey theorem says it takes five percent credibility to deter—this is back in the Cold War—five percent credibility to deter the Soviets, but 95 percent credibility to assure the allies. It's a different goal and to some extent a different set of requirements. There's some overlap, but there also are unique capabilities and declaratory policies that are needed to assure the allies.

And so what the study says is, that assurance should be a self-conscious metric regarding how we put together our forces, not just an after-thought or not something that's a lesser included case. That's why I point to the unilateral withdrawal of TLAM-N. That might have been a good idea for some reasons, but in terms of assuring allies, it was a terrible idea.

We now like to think the Japanese are okay with that move now. Yes, I believe that some Japanese are; but I'll tell you I still have chances to meet with senior Japanese leaders and they often comment unhappily about the unilateral drawdown of TLAM-N. So the point is, you put up assurance as a requirement of itself with its own set of metrics and then you work hard to figure out what that set of metrics requires. It may be completely outside of our notions of deterrence and what we should have for deterrence. But in a sense, that doesn't matter if we want to assure the allies.

If we want to assure the allies we need to live up to those requirements. If we don't want to assure the allies, then we can step back from them. But that's the debate and the tradeoff.

AMB. JOSEPH: Just two points to add. One is on TLAM-N. Here is a case in which we took unilateral action in an environment in which—I'm talking about the theater nuclear imbalance that exists—Russia has an enormous advantage, 8 to 1, 10 to 1. What did we get for it? What did we get for this last unilateral step?

We got nothing for it. And yet, there is a recognition in the arms control community that we have to address the imbalance with Russia. In fact, that's one of the stipulations in the resolution of ratification of New START. Here you have a unilateral action that undercut the prospects, I would argue, for arms control succeeding in terms of achieving our objectives.

And another point I would make is, as in so many other areas, you have to avoid doing stupid things. And I think one of the things that we need to avoid doing is withdrawing the remaining B-61 bombs that we have in Europe. That would be just stupid because once out they're never going back in.

Can you imagine a crisis situation after we've withdrawn these weapons and we're going to put them back in, which is one of the arguments, that we could re-deploy when we need to? I don't think so. I mean, that's just stupid on so many different levels.

And yet, you keep hearing reoccurring calls for taking the last of the weapons out. I think that would be highly detrimental to our extended deterrent in Europe; and, I think it would have a real impact elsewhere. I mean, actions in Asia reverberate in Europe and the same is true in reverse.

DR. PAYNE: Let me just add to that because there's a little piece here we should mention. Bob talked about the drive to withdraw the DCA and the reality of pulling down TLAM-N. Most of the arguments along those lines had to do with military efficiency. I heard all of them for a long time. It always had to do with military efficiency.

And my comment, when I heard the arguments about military efficiency, was, what does military efficiency have to do with assurance? You're conflating two different things. Assurance is a political goal, you get it? It's to hold alliances together. Military efficiency alone may be a third order priority. If it provides assurance, then modernize it so it's not so militarily inefficient.

The minimum deterrence approach conflates virtually everything. The basic presumption that if we can kill—you fill in the blank—number of civilians on the other side, we have deterrence conflates the physical effect of a nuclear weapon with the deterrent effect. Even if you understand the physical effects well, what has that got to do with deterrence? You haven't told me anything about the deterrent effect. Do you have any idea what that is?

Minimum Deterrence says if you have X number of capabilities to destroy X number of societal targets on the other side, you've got deterrence. Really? Again, it's a perfect microcosm of the Minimum Deterrence discussion that conflates things in ways that really are grossly misleading.

MS. : Dr. Payne and Dr. Joseph, the discussion is kind of very emotional because nuclear weapons are bad and it's very hard to have kind of logical sound reasoning once you accept the premise. What are some of the most effective ways to talk about nuclear weapons issues and assurance and deterrence? That might be too long, so pick whatever you want. But what are some of the most effective ways to talk about these issues to kind of counter the religious belief in minimal deterrence?

DR. PAYNE: It's a great question because by asking the question you've captured perfectly what Ambassador Joseph and I are talking about. Largely in the United States, but more exactly within the beltway, nuclear weapons are bad. It's a cultural bumper sticker.

If you go to France, do you think that's true? If you go to the Russian Federation, do you think that's true? If you go to China, do you think that's true? No.

Why? Because they have a different political consensus that isn't captured by the Minimum Deterrence narrative. **The Minimum Deterrence narrative says it's the nuclear weapons that cause the danger. So the goal is to drive them down in number and put boxes around them, and eventually get rid of them, because they're the problem. That is the Minimum Deterrence narrative.** (*Emphasis added by Editor*).

By asking the question, you exactly describe the cultural context, the cultural milieu, that I'm talking about. But it doesn't exist everywhere. It exists very strongly here but not in a lot of other places.

I remember I was watching, during one of the campaigns in India to elect a new leadership, and the person who eventually won was giving a speech. Behind him was a picture of a mushroom cloud. This was to boast about the accomplishments of this regime. You had a mushroom cloud picture. Can you imagine an American leader doing that?

So, that was a long-winded intro, I apologize, but the best way to talk about this is to stand back and ask, what is it that nuclear weapons do? Never mind Doctor Strangelove, On the Beach, all the cultural icons that inform this country about nuclear weapons.

What do they do? They prevent war. The first half of the last century, 100 million casualties—100 million casualties in just over 10 years of combat.

Look at the second half of the century. Admiral Mies has a chart based on a study that actually shows the percentage of deaths in combat. And what you see—I think he took it back about 600 years—what you see is with the nuclear age it drops down to a much lower percentage than the norm up until that point.

There were generally a high annual percentage of combatant casualties until it appears that nuclear deterrence drove that percentage down to the floor.

That's what nuclear weapons do, and that's the way I like to talk about them. If you put it in a medical analogy, they are akin to chemotherapy. They can be really dangerous, but if you don't have them, where do you go?

SHIPBUILDING AND FORCE LEVEL
FUTURE UNDERSEA IMPERATIVES FOR THE
INTEGRATED NAVY

RADM RICK BRECKENRIDGE, USN
OPNAV N91
NAVAL WARFARE INTEGRATION

In my *past lives* I used to spend a lot of my attention focused more or less exclusively on safeguarding the future of undersea dominance. Now, I am officially an undersea *outsider* and I therefore am thankful that the NDIA organizers were willing to throw me a bone and invite me to talk anyway.

In my current position as the Navy’s *warfare integrator* I have a larger perspective. But that different point of view has not changed my sense of what needs to be done in the undersea one bit. In many ways, it might be just the opposite.

Hopefully, I will be able to provide you with a few *action items* to consider as you who remain doers in the undersea community plan for the future.



Looking Ahead at Undersea Investment Imperatives

1	<div style="background-color: #d9ead3; padding: 5px; border: 1px solid black; margin-bottom: 5px;"> Rapidly Changing Strategic Environment </div> <div style="background-color: #d9ead3; padding: 5px; border: 1px solid black; margin-bottom: 5px;"> Implications for the Navy and the Undersea </div>	<ul style="list-style-type: none"> • More overtly aggressive actions by RU, CH, IR and NK • US being called upon to undertake more intrusive leadership • US undergoing internal debate with predictable outcome
2	<div style="background-color: #d9ead3; padding: 5px; border: 1px solid black; margin-bottom: 5px;"> The “Fiscal Reality” Fallacy </div> <div style="background-color: #d9ead3; padding: 5px; border: 1px solid black; margin-bottom: 5px;"> The Urgency of Innovation </div>	<ul style="list-style-type: none"> • US will depend more heavily on the Navy and Undersea • Urgent need for innovation in undersea systems • Increased pressure on undersea nuclear forces
3	<div style="background-color: #d9ead3; padding: 5px; border: 1px solid black;"> Navy Funding and the OR SSBN </div>	



At my new desk in the Pentagon, I have to be a macroscopic thinker—I have to view things from the point of view of the proverbial *high look*.

With that vantage point in mind, I have three goals this morning and I hope to leave you with three big ideas.

First, I want to help you cut through the fog of history and see what is going on with clearer eyes. I want to try to make some sense of these unsettled times we live in and what they mean for the future. I am a bit concerned that we are missing the *signs of the times* and, if we are not careful, very bad things will result. Mark Twain said that “History may not repeat itself, but it rhymes.” He was exactly right. So I will take a minute to look at the rapidly changing strategic environment and how it compares to the past to see if there aren’t some clarifying lessons for the Navy and the undersea community to find.

Second, as many of you know, I have a contrarian view of how to address our Nation’s fiscal future. It is clear to just about everyone that we are on an unsustainable path. What is not so clear is what we should do about it. I worry that we are thinking about the fiscal future in a way that is corrosive and can lead to defeatism and paralysis. I want to bust some myths that have us in an intellectual stranglehold and instead posture us in a way that prepares us for the right future, with particular emphasis on innovation.

Finally, Big Idea number three: I want to talk about the future of Sea-based strategic deterrence and why this is the pivotal year to work with Congress and gain topline relief to fund the OHIO Replacement SSBN.



“May you live in interesting times.”

There is certainly no shortage of challenge in the world we face today. As Deputy Secretary Work said last month, it is, of course, both a privilege and a burden to be in a position of responsibility when we are facing a national security environment that is as challenging as any of us can remember.

There are many different *theaters of operations* from the Ukraine to Iraq to Afghanistan to the Cyber domain to the South China Sea to North Korea to Africa. In each theater, events are moving quickly and there are many players wearing hats that aren't white or black, but are instead shades of gray. And they are changing hats depending on the situation at hand. This is a very complex problem, and the world that our children will face depends on how we handle these churning trouble spots. In many ways it is hard to see what we should do.

There is a tendency when confronted with such complexity and such huge stakes to long for simpler times. I have heard people wish for greater clarity about good-guys and bad-guys. They disdain the sort of twilight conflict we have today. Some think back to World War II. Sure Nazi Germany was a horrific genocidal foe, but at least it was crystal clear at the end of the day it was clear who was who in that fight. Ah, those were the days of clarity.

 While the “Greatest Generation” Debated...	
18 Sep 1931	Japan invades Manchuria (9/18 still a black day in China)
7 July 1937	Japan invades China
13 Aug 1937	Battle of Shang-hai
13 Dec 1937	“Rape of Nanjing” (which was then the Chinese capital)
12 Mar 1938	Anschluss (annexation of Austria by Germany)
15 Sep 1938	Sudeten Crisis and Munich Appeasement
1 Sep 1939	Germany invades Poland; Soviet Union later follows suit
14 Oct 1939	U-47 sinks the <u>Royal Oak</u> at anchor in Scapa Flow, Scotland
30 Nov 1939	Soviets invade Finland
9 April 1940	Germany invades Norway and Denmark
10 May 1940	Germany invades Belgium, Netherlands, France
21 June 1940	French surrender
17 Aug 1940	Hitler declares U-boat blockade of Britain
20 Aug 1940	Battle of Britain between RAF and Luftwaffe
7 Sep 1940	Germans start London Blitz – indiscriminate nighttime bombing
26 Sep 1940	Japanese invade French Indochina
11 Mar 1941	FDR signs Lend Lease Act
27 May 1941	British sink the <u>Bismarck</u> off Brest, France
22 Jun 1941	Germany invades Soviet Union

But wait a minute. Sometimes when we read about the Greatest Generation, we think that everything back then was so clear about friends and foes.

That’s not really how it went. We have to remember that the clarity about good and bad only came with time. And, unfortunately, the clarity only came because we allowed the situation to degrade so dramatically that there was no longer any doubt about right and wrong, white and black, good and bad.

To those who were living it—to regular Americans—there were a number of years when the situation was not so clear. It is easy to forget those years from 1937 or so to our entry into World

War II. During that time, we were struggling as a country for alignment and direction.

Japan had invaded Korea and China, was bombing cities, and had killed tens of thousands of civilians and we did virtually nothing. Germany was systematically taking German-speaking territories from their neighbors with the justification of ethnic consolidation. This should sound familiar. We looked on while Austria was coercively annexed, while Prime Minister Chamberlain appeased, while the Czech Republic was carved up, while Poland was invaded, then Denmark and Norway, then the Low Countries and France. They all fell to Germany. Russia was invaded and the Wehrmacht was in the suburbs of Moscow.

But what about the Good Guys? What was the UK doing through all of this? More importantly, where was the United States?



The UK Decides: 4 June 1940

"Even though large tracts of Europe and many old and famous States have fallen or may fall into the grip of the Gestapo and all the odious apparatus of Nazi rule, we shall not flag or fail.

We shall go on to the end. We shall fight in France, we shall fight on the seas and oceans, we shall fight with growing confidence and growing strength in the air, we shall defend our island, whatever the cost may be. We shall fight on the beaches, we shall fight on the landing grounds, we shall fight in the fields and in the streets, we shall fight in the hills; we shall never surrender,

and if, which I do not for a moment believe, this island or a large part of it were subjugated and starving, then our Empire beyond the seas, armed and guarded by the British Fleet, would carry on the struggle, until, in God's good time, the New World, with all its power and might, steps forth to the rescue and the liberation of the old."

-- Prime Minister Winston Churchill in the House of Commons, 4 June 1940

Notice that even at this early date Churchill foresaw that it might all depend on the United States



In 1940 as France was falling to Hitler and the British Army was being evacuated from Dunkirk, there was a debate in Britain about how the UK should respond to German aggression. Should the UK make a treaty with Germany to stop further conflict and protect the Empire from a struggle that the UK could not win? Or should they resist?

What did public opinion say in the UK? Well, I can tell you that that there was no hint of ambiguity, but the answer may not be what you think. Something like 80 percent of Britons wanted the government to make a treaty with Hitler to prevent war.

When British Prime Minister Chamberlain came back from Munich after making a deal with Hitler, there was national giddiness that another terrible war had been averted. “Peace in our time,” the Prime Minister proudly claimed. But within weeks the enthusiasm had worn off.

By the middle of 1940, after most of Europe had fallen, the awful reality became clear to the U.K. Britain would have to fight. As Churchill said, Britain would fight in the air and on the sea and on the beaches and in the streets and in the hills. And notice that even in 1940, Churchill clearly distinguished between what Britain would do – “we will never surrender”– and what the “New World” could do: “[step] forth to the rescue and liberation” of Europe. He knew that the U.K. could resist evil, but only the U.S. could roll evil back.



May 1941: Isolation versus Intervention Tension

27 May FDR Radio Speech: "As had happened so often before, the president, having talked tough, backed away from all notions of belligerency. There would be no convoying, at least for the present; no repeal of the neutrality law; and no fighting....Throughout the country, there was a sense of deflation."

LIFE Magazine: "On your marks, he has said to the nation, for a race with destiny....Get set for the greatest effort of our history. Then, while the people waited poised and tense, he tucked the starter's gun back in his pocket and went off to a Hyde Park weekend."

Janes All the World's Aircraft editorial: "The United States has decided to support the war "down to the last Englishman.""

Diplomat Averell Harriman to a friend: "It is impossible for me to understand the ostrich-like attitude of America. Either we have an interest in the outcome of this war or we have not....If we have, why do we not realize that every day we delay direct participation...we are taking an extreme risk that the war will be lost."

Lynne Olson, *Those Angry Days*, 2014, pp 307-308.

And what was the U.S. response?

A full year later we were still engaged in a massive internal debate about whether this was our war or not. Shouldn't we just mind our own business? Look at how our indecision was addressed at the time. FDR knew that we needed to intervene but the American people lacked the will to engage.

This was a painful part of our history, a time that most people were all too happy to forget about once Pearl Harbor had occurred and we were in the war for sure.

I review this little piece of history because I want to remind everyone here that history is not so clear when it is in the process of occurring. What to do and where to go is foggy and ambiguous. This has always been the case, especially for the United States,



which by our geography has the option of sitting behind an ocean-sized moat and watching.

What we are going through today is the same sort of unsettled swirl that our grandparents faced in 1939 – and the stakes may be as high. Again, I am not saying that history is repeating itself, but doesn't it seem like it rhymes? So, like our grandparents and the leaders of the United States back then, we need to stop feeling sorry for ourselves. If we want clarity, we need to look through the fog and see the patterns, the trends, and the major movements. We need to see the forest and stop worrying so much about this tree and that tree.

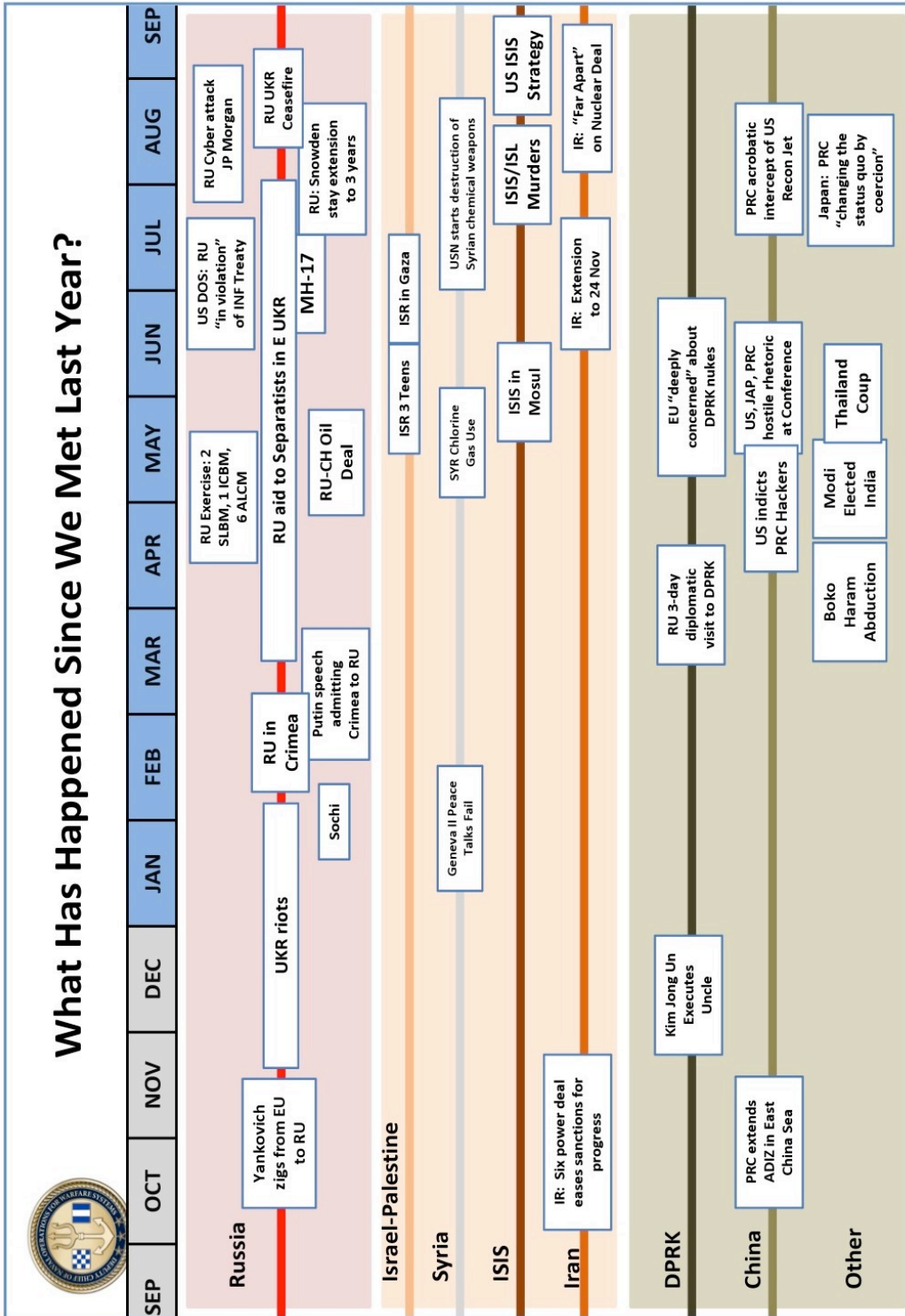

So, let's fast forward to the present. What has happened over the past year?

Last September, if I had described for you the series of events that would happen in the next 12 months, you would have laughed me out of the room as some sort of alarmist.

Seriously—and I do mean this seriously—when you go through this timeline, it looks like the read-ahead for some sort of exercise war game or the plot outline of a paperback novel. It had better get your attention. We are not in Kansas anymore.

What has taken place?

The Russians have seized territory in the Ukraine...to protect the rights of Russian speaking people. Just like those German speakers in the Sudetenland were protected, by the way. The Russians laid down the keels of not one but three different nuclear submarines of three different classes on the same day. They conducted a single integrated nuclear exercise with the launch of ICBMs, SLBMs, ALCMs and defensive missiles all with Putin in the Command Center to observe. They have rejected the notion of further nuclear weapons reductions and have speculated publicly that perhaps they should formally make the US and NATO their enemy. Remember that the Russian government now controls the Russian media—there is no chance that such speculation gets released to the West by accident.

This time last year there was no such thing as ISIS. There were some especially radical Islamists that were too far out for Al Qaeda to embrace. Then they started calling themselves the Islamic State of Iraq and Syria. But then this wasn't grand enough. They changed the name to Islamic State of Iraq and the Levant (now adding Lebanon, Israel, and Jordan to the target set). That was ISIL. Then they became The Islamic State – clarifying their ambition for dominance of the Islamic world. Beheadings—not just Americans, but also Brits and Kurds. And the captured Syrian soldiers they just lined up by the hundreds along a sand berm and shot them all dead en masse. Then they released the videotape.

A year ago, we had just given Syria a reprieve for being punished for their chemical weapons attack which killed hundreds of civilians. Now, we have finished destroying their *declared* chemical weapons, but the Syrians are still using chlorine weapons on civilians. Saudi Arabia and the UAE have started conducting air strikes in this conflict.

The Chinese continue a rapid naval build-up. They have had skirmishes with both Vietnam and the Philippines. They have resumed aggressive aerobatic flying when close to our surveillance aircraft. They have gone off script to use uncharacteristically hostile language against our leadership. They have been provocative to Japan.

We have made little progress with our nuclear negotiations with Iran. During this last year we made an agreement to talks, staving off fear of a US or a US-Israeli attack. Then, when the deadline was reached in July, an extension was granted to November. A few days ago the media reported that the parties are *far apart*.

The US has been victim of cyber attacks from Russia, from China and from Iran on a major scale, targeting both government and commercial interests.

In short, events are careening in a direction that is bad. It is more confrontational with more adversaries and across more fronts with more complex interactions. The heat on the global kettle has been turned up and it is starting to boil. I dare not speculate on what the next 12 months will hold.



Open Source



A quick aside to emphasize one point. I mentioned briefly that the Russians had laid the keels of three nuclear submarines on the same day—Russians Navy Day last July.

This photo appeared in open source social media. Some guy named Ilya was able to buy the last three pens at the SEVMASH shipyard gift shop and tweeted this prized photo.

The blue pen on the bottom is Hull 5 of the Delta IV replacement, the Russian equivalent to the *Successor* class of SSBNs. If the Russians keep up this pace they will commission the 10th SSBN replacement by 2020, one year before we lay the keel for the first OHIO Replacement.

The red pen is Hull 4 of the SEVERODVINSK class. The four hulls that will follow—hulls 5 through 8—are also on path to be commissioned by 2020. I remind you that SEVERODVINSK is equivalent to a stretched SEAWOLF with not 4 but 8 large diameter missile tubes. So, they will have something like 8 SEVERODVINSK submarines in service with 8 large tubes each by 2020—and remember these are not SSBNs and are not part of any treaty restriction. By our current plan, if we are lucky, by the same year 2020 we will have started construction on our first submarine with the four-tube VIRGINIA Payload Module—it will not enter service until years later.

The white pen is a bit mysterious. Some say it is SEVERODVINSK Hull 5. However, if you look closely, you can clearly see that the silhouette is different. In any case, it is a third nuclear submarine, of a third class, being started in the same yard. Now, back to U.S. national will. Some in Washington are getting nervous at the impact that the VPM might have on our ability to successfully build the OHIO Replacement SSBN at the same time. They worry this will be too hard. They worry we don't have the industrial capacity to do this without jeopardizing our number one priority. Meanwhile, with an economy the size of Italy's, Russia has started three nuclear submarines on the same day.

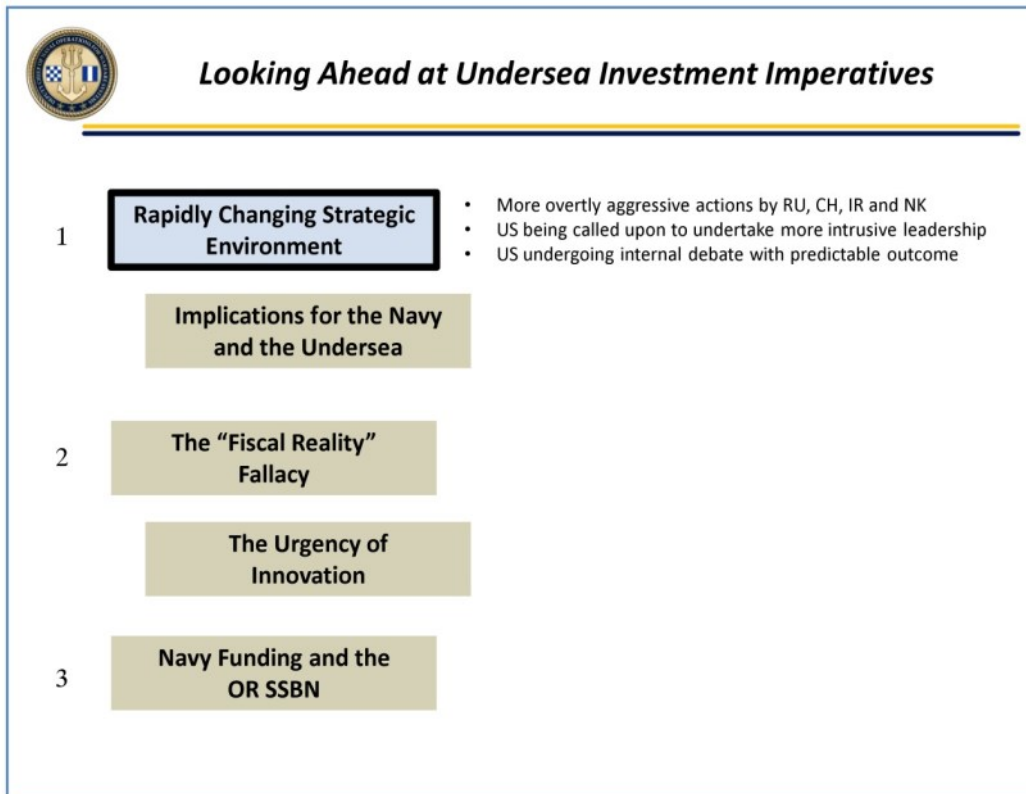

So now is not the time for us to go *wobbly-kneed*. If we are intent on remaining the world’s dominant undersea force, then we ought to start getting moving.

While the rest of the country dithers in a public debate about war weariness, we need to take a lesson from history. We have seen this movie before and we know how it will end.

The work of the NDIA undersea community is more vital and more urgent than at any other time in history. We may be proud of *2-Sub Joe* but we cannot forget *3-Sub Ilya*.

So, unlike our grandparents back in the late 1930s, we have the benefit of experience. There is no question where the big arrow of history is pointing. We know what we must be able to do, even if it will take a while for the rest of the country to catch up. Remember, back in the late 1930s it took us time to get ourselves moving, too.

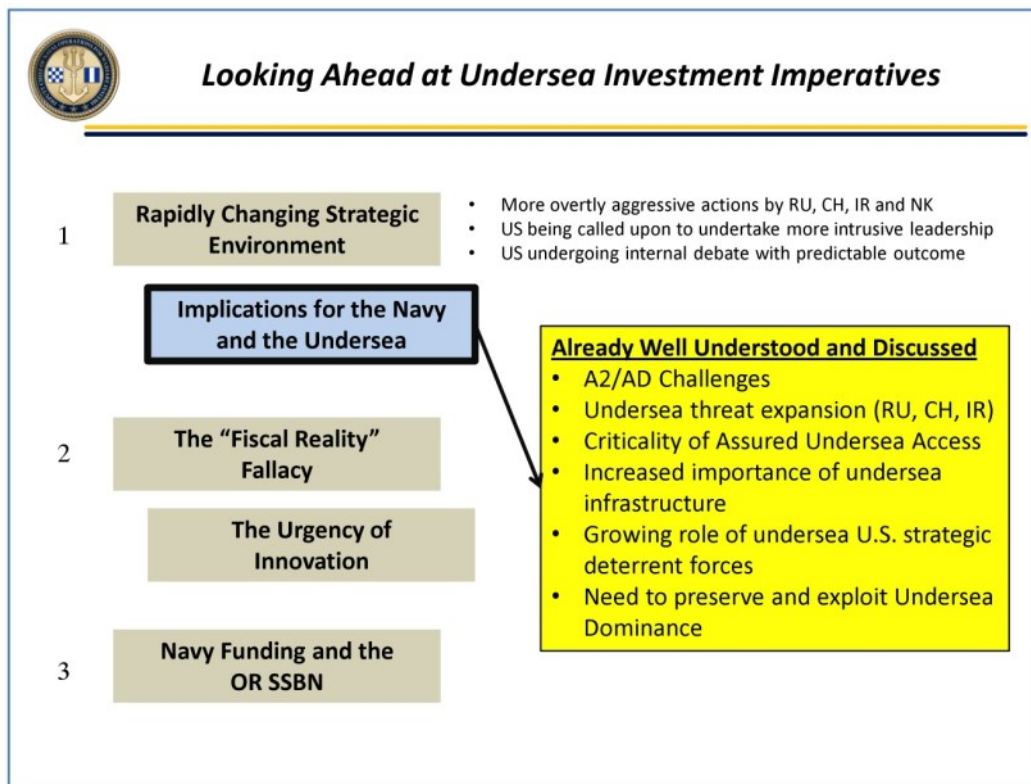

This need for a more assertive America has particular implications for our undersea forces.

This is a topic that has been addressed by others at this conference. I will not repeat the arguments in detail, but I will remind everyone here of the conclusion.

- The proliferation of A2AD systems and capable undersea forces has made it doubly important that our own undersea forces be prepared to assume an increased role.
- The pressure on our part of the nation’s nuclear deterrent is great and will be even greater.
- The importance of preserving our undersea dominance has become even greater as our dependence on the undersea has grown.

So, Big Idea Number One: The global security environment is rapidly changing, and it is changing in a way that will place increased demands on the United States, the Department of

Defense, the Navy and on our Undersea Forces. It took us time to get ourselves moving in the late 1930s, but eventually we figured out that we had to walk less softly and start swinging the Big Stick.

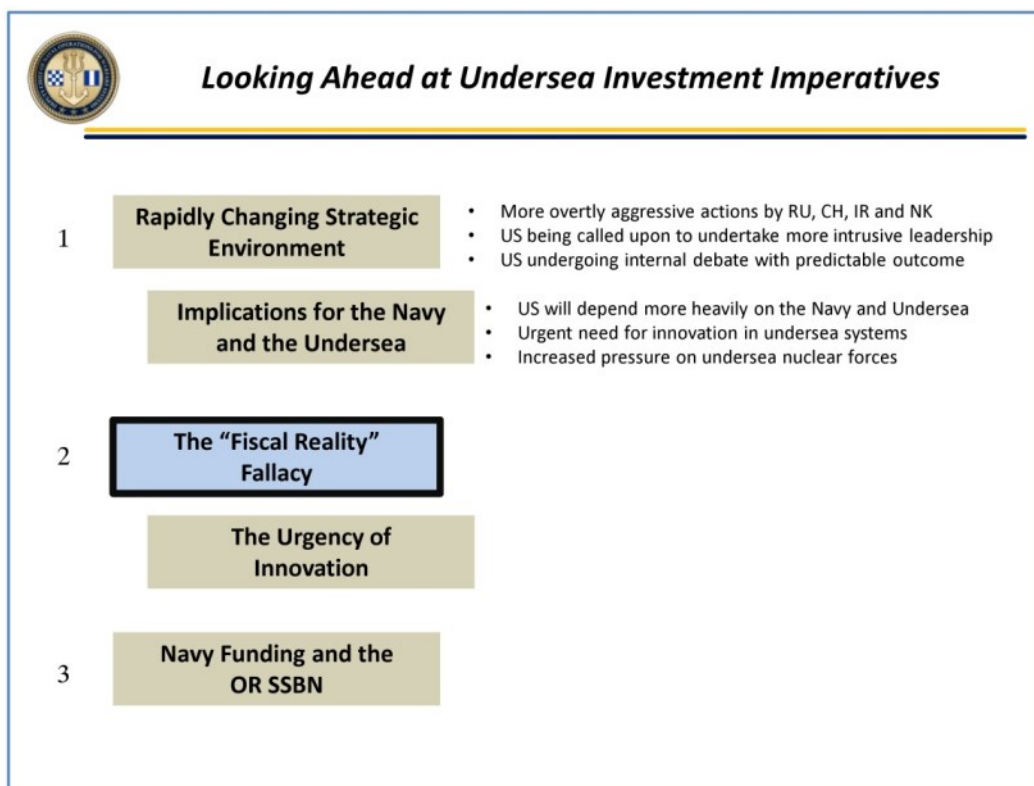

Now, let's move on to the Second Major Point – the Nation's response to the fiscal challenge. This is an area that may present an even more formidable challenge than the threat itself.

We have fallen into a trap of *wrong think* about our economic health as a nation. Too many people for too long have argued that *fiscal realities* make it inevitable that our defense budget, and along with it, our Navy budget must shrink.



The “Fiscal Reality” Fallacy

“In a real sense, the debate over whether BCA sequester-level cuts will be lifted by FY 2021 is moot, because the larger vise on the U.S. federal budget – caused by the growing gap between entitlement programs spending and government revenue – will result in a deep defense drawdown.”

-- CSIS: “Building the 2021 Affordable Military,” p. 3

Wrong.

Not only are “deep defense cuts” not “inevitable” – they are not even *reasonable*.
We need to stop repeating this flawed premise

Let’s talk about it and make sure we get our facts and reasoning straight.

There is a loud chorus who make the case that even with a growing threat, an increase in defense or Navy spending is not in the cards. They argue that this trajectory is unaffordable.

They say that we as a country have a budget that is too tight and we have too many other fiscal burdens to permit increasing defense spending. They argue that we have “no choice but to plan for declining defense expenditures.”

I reject this notion.

This slide shows a recent example. CSIS recently put out a study called *Building the 2021 Affordable Military*. Now, this study says that we should have something like 60 attack submarines and a robust SSBN force and that we must place much more emphasis on a solid Navy. I love all of these conclusions. What I reject is their starting premise that the defense budget must be reduced.



CSIS is not alone. This idea that defense spending must be reduced has been repeated by so many for so long that it has become a kind of conventional wisdom or urban legend. Unfortunately, it is an incredibly destructive idea, and we have no choice but to figure out how to pull it out by the roots.

Happily, it does not require a very technical argument to prove that this *fiscal reality* argument is totally wrong.

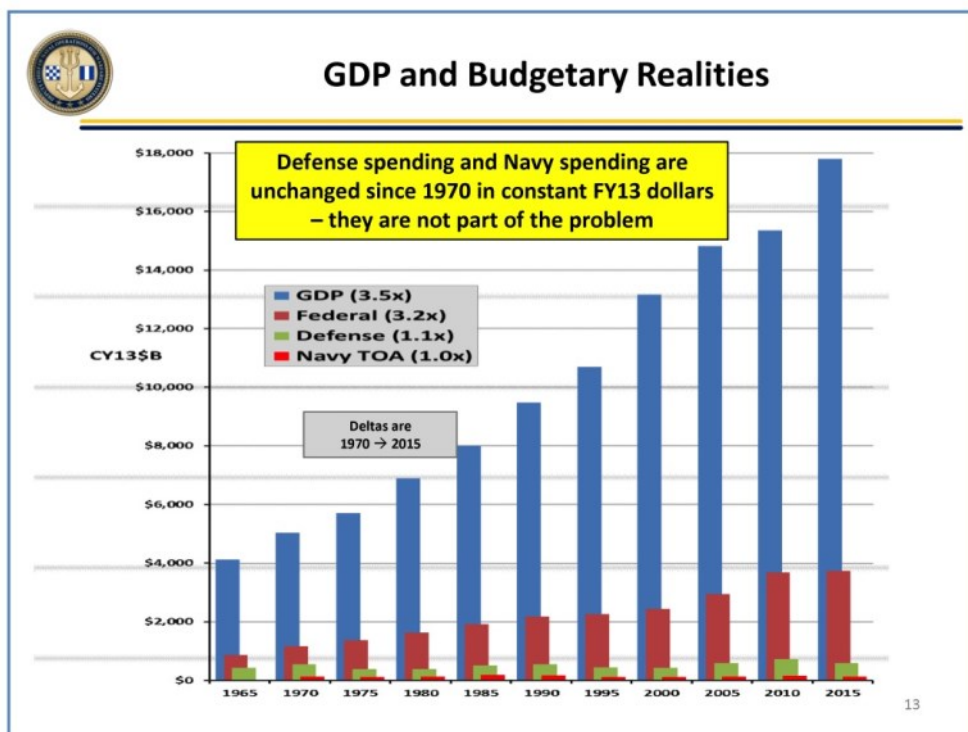

Let's quickly walk through the argument so you all are comfortable refuting the *fiscal reality* nonsense whenever you hear it. I have a simple three point case.

First point. The Navy budget is not part of the problem. I showed you this chart last year. In constant dollars, the defense budget has barely grown since 1970 and the Navy budget has not grown. On the other hand, the national economy is almost four times as large as it was, as is the federal budget.

When spending on everything else has gone up three or four or eight times, and your spending is unchanged, you are not at fault for the budget problem. In fact, you have been effectively helping to reduce the speed at which the budget has grown.

And remember, what have we the Navy-Industry team done with the flat budget? We have gone from synchro-motors to digital systems to computer systems to networked warfare systems. We have introduced precision strike, GPS, and integrated space systems. We have transitioned to vertical launch systems. We have introduced unmanned systems and cyber warfare. We have undertaken counter-terrorism, techniques to enforce maritime sanctions on abusers, and transitioned from blue water operations to dynamic littoral operations in shallow, crowded water. The Persian Gulf used to be too shallow for submarines. Not any more.

All of this has been done on an essentially flat budget. This is a remarkable achievement. It is a credit to the cost-efficiency and leanness that is tightly integrated into today's navy as compared to that of 1970.



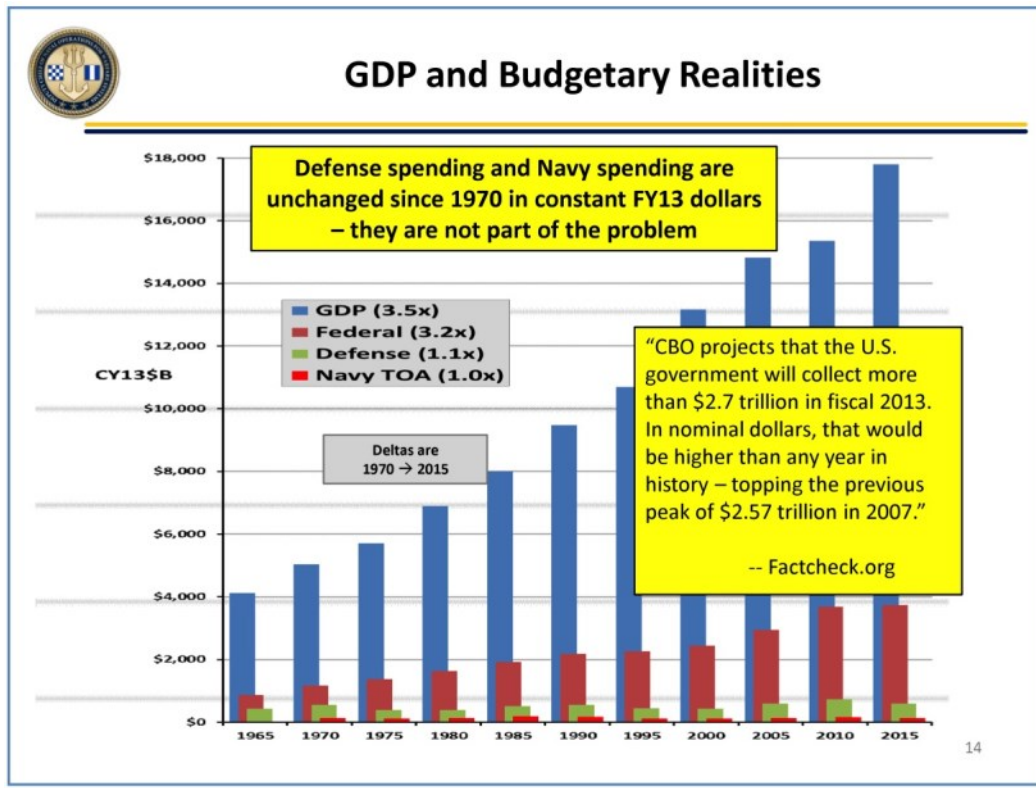

Point number two: the national resources are there.

The US economy is bigger this year than it has ever been in history – and that is in constant year dollars. In addition, the revenue collected by the federal government this past year was more than it has ever been in history. It is not an issue of whether we have the money. Teenagers are fond of saying that they “didn’t have time” but what parents know they really mean is that they did not choose to spend their time wisely.

We have the wealth as a nation to fund our current and future military at the right levels, there is no question. We have more money than ever. We don’t have to punish defense spending because we haven’t been able to figure out how to manage the resources of the wealthiest nation on the planet.

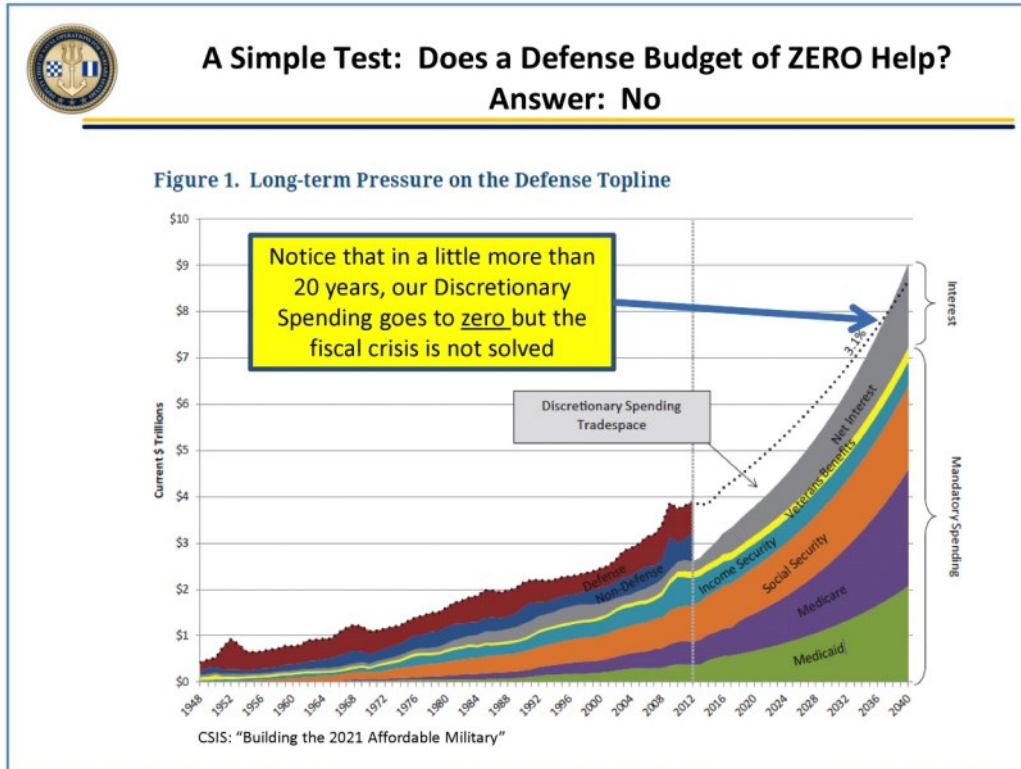

Point number three: You can do a simple test to prove that reducing the defense budget is not *inevitable*.

Here is a graph you will see in various forms again and again. This one is from the same CSIS report I mentioned above. It has a history of US federal spending and then projects the future based on these past trends. The 3.1 percent envelope at the top is an assumed economic growth in the future of 3.1 percent.

Notice that if all trends continue without interruption, by 2036 or 2037, our discretionary spending in the US will decline to zero. And before that, it will get smaller and smaller, year by year. This is why, these studies say, that realism requires reduced defense spending.

Now here is the test. Ask yourself if the defense budget were reduced to zero...not reduced, but eliminated – would it solve the fiscal problem we face? The answer is right on the graph. No. We can see from the trend lines that even if all defense spending and all other discretionary spending were zero, we still will be following a fiscally unsustainable path. The other parts of the

budget will overwhelm our available resources. We will still fiscally collapse.

Well, if there is any trend that we can safely say will NOT be followed, it is this one. There is no chance discretionary spending is going to be driven to zero and there is no chance that this road will lead to fiscal success. So, if we know that this is the wrong road, why would anyone argue that it is essential for us to head down that road?

Why do otherwise thoughtful people repeat this fiction as if it is accepted wisdom, come down from the mountain in stone?



The Actual “Fiscal Reality”

Would Zeroing all discretionary spending solve the fiscal problem?
-- No.

Would Zeroing all discretionary spending create unacceptable new problems?
-- Yes.

Are there ways to solve the fiscal problem that do not involve cutting discretionary spending?
-- Yes.

What are some examples?

- Reduce “non-discretionary” programs (entitlements)
- Increase taxes
- Grow the economy more quickly
- Some combination of the above steps

This future will not occur. Something is going to have to disrupt the trend to preserve discretionary spending at an appropriate level. Zeroing discretionary funding won't fix the problem. Instead zeroing discretionary spending would create a host of new problems. So that's not the answer.

Are there other options? Yes, there are. There are a variety of ways to hold discretionary spending at an appropriate level. What are some of the alternatives?

- We could reduce non-discretionary funding (entitlements)
- We could increase taxes
- We could grow the economy more quickly
- We could do some combination of these steps.

These choices are not hard to see. My place is not to choose which of these options are used, but I do think it is important to reject the notion that a Navy cut is inevitable over the mid to long term.

Indeed I see the opposite. And I think it is dangerous to confine our imagining of the future to exclude more robust defense options, especially since those may in fact be exactly what the nation will direly need.



Looking Ahead at Undersea Investment Imperatives

1	<div style="background-color: #d9ead3; padding: 5px; margin-bottom: 5px;">Rapidly Changing Strategic Environment</div> <div style="background-color: #d9ead3; padding: 5px; margin-bottom: 5px;">Implications for the Navy and the Undersea</div>	<ul style="list-style-type: none"> • More overtly aggressive actions by RU, CH, IR and NK • US being called upon to undertake more intrusive leadership • US undergoing internal debate with predictable outcome
2	<div style="background-color: #d9ead3; padding: 5px; margin-bottom: 5px;">The Urgency of Innovation</div>	<ul style="list-style-type: none"> • US will depend more heavily on the Navy and Undersea • Urgent need for innovation in undersea systems • Increased pressure on undersea nuclear forces
3	<div style="background-color: #d9ead3; padding: 5px; margin-bottom: 5px;">Navy Funding and the OR SSBN</div>	<ul style="list-style-type: none"> • The flat Defense/Navy budgets are not part of the problem • Even <u>zeroing</u> the Defense/Navy will not solve the fiscal problem • Further Defense/Navy cuts will <u>aggravate</u> our problems



So, Big Idea Number Two: Our flat Navy budget over the past four decades is not the source of our current national fiscal problems, and cutting it further is not the solution to those problems.

Reductions to the defense budget will not fix the problem.

Further cuts are more likely to cause additional problems by emboldening adversaries, disheartening allies and undermining international economic confidence.

I am not suggesting that the near-term outlook for Navy funding is solid. This is not so clear. We may have to weather another bumpy year or two, just as it took some time for the Greatest Generation to get their bearings. But we should not equate near-term uncertainties in Navy funding with long-term uncertainties. As the pressure from growing threats continues to accumulate and the true source of our fiscal problems becomes clearer, we can expect our heading to be adjusted appropriately.

That brings us to our next point – the importance of innovation.

Looking Ahead at Undersea Investment Imperatives

- 1 **Rapidly Changing Strategic Environment**
 - More overtly aggressive actions by RU, CH, IR and NK
 - US being called upon to undertake more intrusive leadership
 - US undergoing internal debate with predictable outcome

Implications for the Navy and the Undersea

 - US will depend more heavily on the Navy and Undersea
 - Urgent need for innovation in undersea systems
 - Increased pressure on undersea nuclear forces
- 2 **The “Fiscal Reality” Fallacy**
 - The flat Defense/Navy budgets are not part of the problem
 - Even zeroing the Defense/Navy will not solve the fiscal problem
 - Further Defense/Navy cuts will aggravate our problems

The Urgency of Innovation
- 3 **Navy Funding and the OR SSBN**

While we as a nation are debating the degree to which we want to engage internationally and the degree to which we can afford to invest in the Navy, the challenge we are facing is only growing. While we wait for consensus to build, we are providing our adversaries the time to invest and learn and plan and test. All through that process they will be creating new challenges we will have to overcome when we awaken.

So, in the undersea forces we have to be aware of this dynamic and take steps to counteract it. The key is aggressive innovation. Admiral Connor’s Undersea Dominance Campaign Plan includes a systematic pursuit of innovation to kick-start undersea forces innovation in several key areas. This is necessary, but it is not sufficient.



Innovation and the “Near Death Experience”

Must we wait for a “near death experience” to embrace innovation?

- No. Even if all Near Death Experiences led to innovation, it wouldn’t mean that all innovation came from Near Death Experiences
- We don’t want to wait for a big gap before we innovate
- We better be smart enough to see gaps coming and prevent them
- Is the iPhone the result of a “near death experience”?

Is there urgency in innovating today?

- Yes. When the resources become available, those with the most mature and potent technologies will receive the investment

Are we ready to answer the investment bell today?

- Not yet. Think of the UDCP capabilities that are not yet mature
- Ask whether your industry has proven its readiness to expand production

Today: Time but little money → Innovate!
Tomorrow: Money but little time → Build what you have innovated

We have a special duty over the near term to innovate so that over the mid to far term we are ready with the right technologies and capabilities.



Some would say that we always can come up with the essential innovations once we have that life-changing brush with mortality.

I reject this idea.

Who is to say that we will be able to recover quickly enough or that we will have the time to react? In September 1939, the Poles and the Norwegians and the French were all unable to innovate fast enough to keep German lightning warfare from over-running them.

And what about Apple? Do they wait for imminent business failure before they come up with a new idea? Is their approach to wait for a *gap* and then figure out how to fill it? Not a chance. Apple wants dominance, so they need to innovate on their own aggressive schedule. We want dominance, too, and therefore we must innovate aggressively. If we are standing still, we are being over-run.

Think about it this way: today we have time, but we don't have enough money. But hopefully you can see a day coming where these restrictions will be lifted and then we will have money, but we will have no time. The resources will be there, and leadership will be asking for urgent action. Those who are ready with compelling and mature investment plans will get that money when it becomes available.



Looking Ahead at Undersea Investment Imperatives

1	<div style="background-color: #d9ead3; padding: 5px; margin-bottom: 5px;">Rapidly Changing Strategic Environment</div> <div style="background-color: #d9ead3; padding: 5px; margin-bottom: 5px;">Implications for the Navy and the Undersea</div>	<ul style="list-style-type: none"> • More overtly aggressive actions by RU, CH, IR and NK • US being called upon to undertake more intrusive leadership • US undergoing internal debate with predictable outcome <ul style="list-style-type: none"> • US will depend more heavily on the Navy and Undersea • Urgent need for innovation in undersea systems • Increased pressure on undersea nuclear forces
2	<div style="background-color: #d9ead3; padding: 5px; margin-bottom: 5px;">The “Fiscal Reality” Fallacy</div> <div style="background-color: #d9ead3; padding: 5px; margin-bottom: 5px;">The Urgency of Innovation</div>	<ul style="list-style-type: none"> • The flat Defense/Navy budgets are not part of the problem • Even <u>zeroing</u> the Defense/Navy will not solve the fiscal problem • Further Defense/Navy cuts will <u>aggravate</u> our problems <ul style="list-style-type: none"> • Innovate today so we can build tomorrow • Cannot afford to wait for the “near death experience” • UDCP and IUFS provide solid innovation guidance
3	<div style="background-color: #d9ead3; padding: 5px;">Navy Funding and the OR SSBN</div>	

We have to take a page from our own history of doing incredible things with restricted resources and realize that there is something that we can do while we wait for the *mid-term to far term* to arrive.

Think of the general list I gave you earlier of the amazing innovations the Navy had made under conditions of a flat budget. Now, think of VADM Connor’s Undersea Dominance vision. Think of the video he showed about 2025. That future is not one that can be executed with existing technology. It depends on aggressive innovation. We have more work to do. Although we have a lot of *rough ideas* about what we want, we really haven’t done enough head work and testing to be sure of what to invest in.

We are still bumping around on a fiscal dirt road with ruts and potholes. But up ahead, we can see the smooth pavement. We want to get the R and D done now, so that when we reach the asphalt, we can floor the accelerator. We need to hurry in getting our thinking clear and lean forward with our innovation efforts in order to be ready.



Looking Ahead at Undersea Investment Imperatives

1	<div style="background-color: #d9ead3; padding: 5px; margin-bottom: 5px;">Rapidly Changing Strategic Environment</div> <div style="background-color: #d9ead3; padding: 5px;">Implications for the Navy and the Undersea</div>	<ul style="list-style-type: none"> • More overtly aggressive actions by RU, CH, IR and NK • US being called upon to undertake more intrusive leadership • US undergoing internal debate with predictable outcome
2	<div style="background-color: #d9ead3; padding: 5px; margin-bottom: 5px;">The “Fiscal Reality” Fallacy</div> <div style="background-color: #d9ead3; padding: 5px;">The Urgency of Innovation</div>	<ul style="list-style-type: none"> • The flat Defense/Navy budgets are not part of the problem • Even <u>zeroing</u> the Defense/Navy will not solve the fiscal problem • Further Defense/Navy cuts will <u>aggravate</u> our problems
3	<div style="background-color: #d9ead3; padding: 5px; border: 2px solid black;">Navy Funding and the OR SSBN</div>	

Finally, number 3. We have to be crystal clear with ourselves and with others that the SSBN replacement **MUST** be our top priority as we grind through the plan to confront a challenging future. There is no room to waiver on the New SSBN.

Earlier, I stressed that we must be able to move forward on several different fronts at the same time. If the Russians can build a replacement SSBN, a double-wide SSGN and wickedly intimidating payloads all at the same time, then we should be able to do much better.

But make no mistake, the priority of ultimate first importance is getting OR design, construction and certification completed on time. The challenge we face is not simply colossal...it is the driving imperative of our ultimate security as a nation and the hinge upon which all other facets of our conventional power swings.

Some people hear words like this and treat them as mindless worship on the old discredited nuclear altar. I think such an attitude is dangerously unrealistic. We may wish it were not so, and it may be uncomfortable for us to think about, but the

overwhelming evidence shows that there are many nations who depend on nuclear weapons today for their security and will depend upon nuclear coercion in the future for international influence. There are more than 30 nations that depend on our extended nuclear deterrent as justification for not pursuing their own nuclear weapons programs.

We must ensure that, even as the nuclear challenge intensifies from Russia, China, North Korea and potentially others, the effectiveness of our deterrent remains ironclad in the minds of our adversaries and allies.

Let me show you a quick series of slides that will illustrate the stress that will come with our SSBN future. We have, to some degree, chosen a path that has us cornered with only one way out – we must not only make our OHIO SSBNs last but we must also make our OHIO Replacement SSBNs show up on time, ready for their first patrol.

Fielding the Replacement SSBN is the largest challenge facing the undersea community, and the Navy-Industry team cannot fail in this mission.

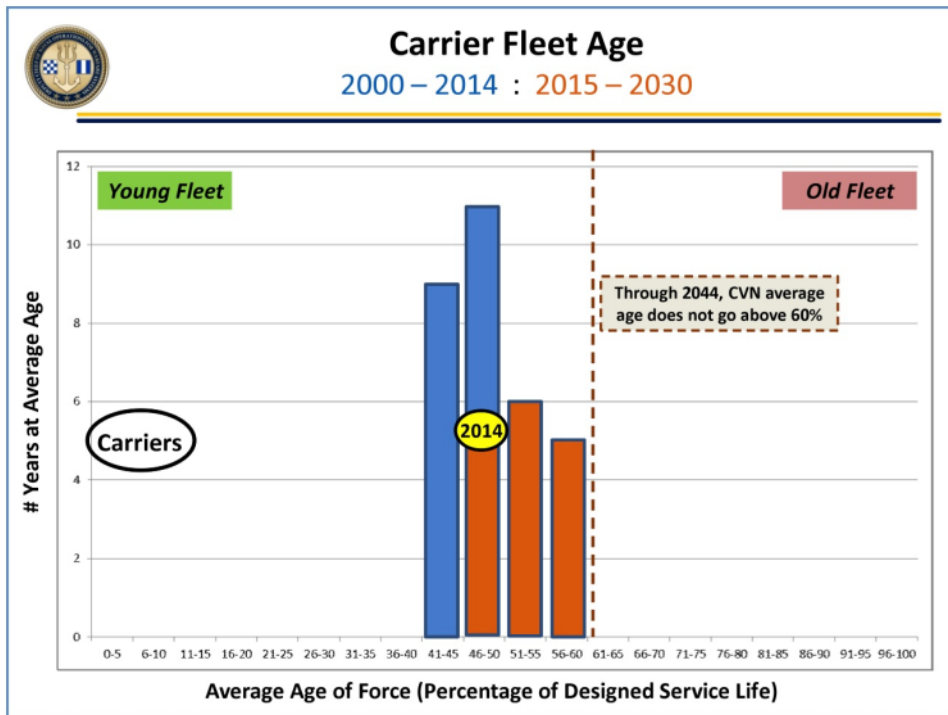

As the Director of Naval Warfare Integration, I watch the age of our fleet closely. I have to ask “is the balance right? Where are the risks too high? Where can I assume greater risk?”

These next few charts depict the average age of major parts of our fleet expressed as a fraction of expected life. We use this approach because it lets us look at different ships with different lifespans using a common metric – it lets us *normalize* the data.

What does *good* look like on such a graph? The ideal steady state force is hovering at the right level with new ships matching retirements. In this ideal case, the average life of the force is steady at about 50 percent of service life.

Trending young might be good, such as in the LCS example, or it might be indicative of other problems, such as when we decommission old ships faster than we build new ships.

Trending older on the other hand, is basically never a good thing.

On this graph we show the average age of the carrier force with the last fifteen years in blue and the next 15 years in orange. We grow a little older, but the average CVN Fleet Age never exceeds 60 percent of service life. This is a good, tight, nearly ideal practical case.

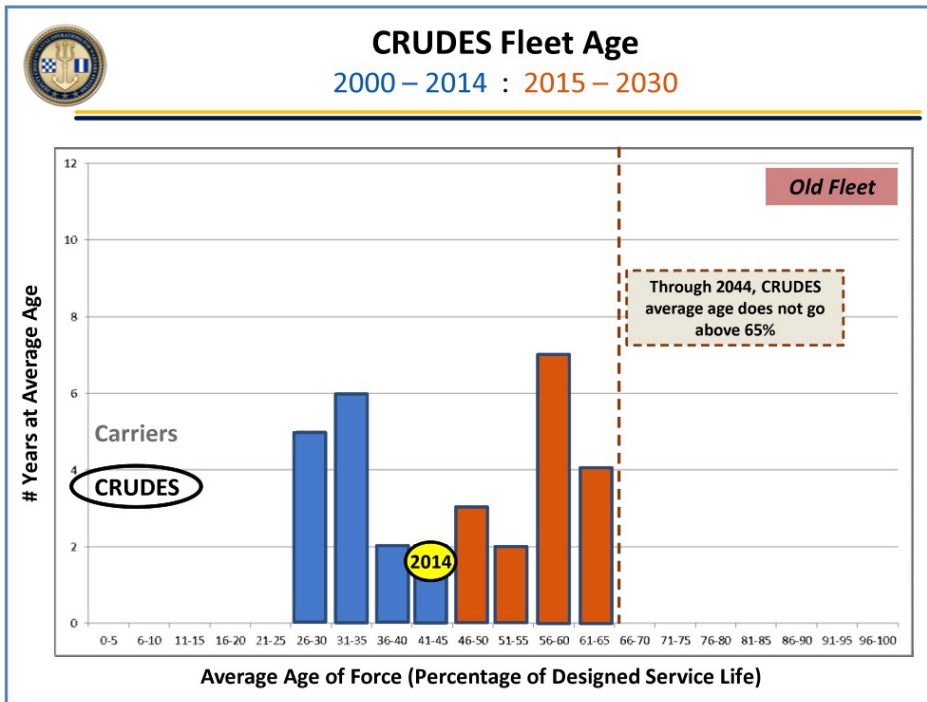

For our Cruisers and Destroyers, the story is about the same. The gray in the background is from the carriers. This part of the Navy is basically good and stable with more variance around the mean than we saw with the carriers.

What about our SSNs?

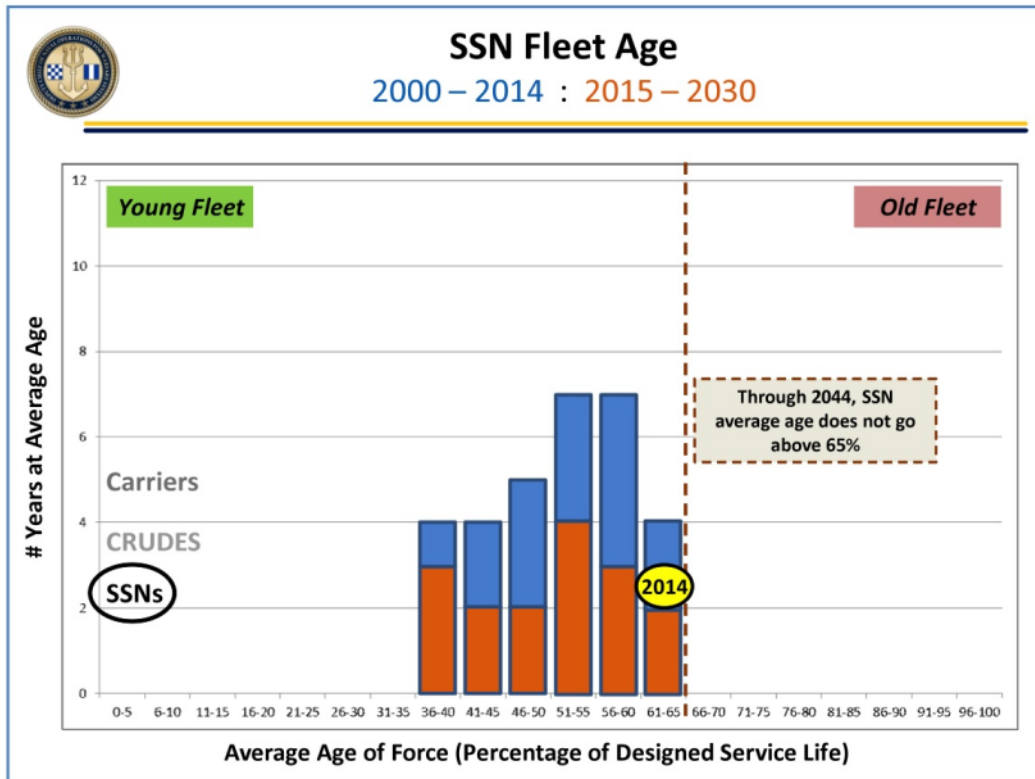

For SSNs, 2015 is a key year. Our average SSN Fleet Age as a percentage of service life will top out at about 65 percent – the same as we saw with CRUDES – and then over the next 15 years it will decline.

What is the source of this *trending younger*? It is the result of aggressively retiring LOS ANGELES class SSNs at a rate faster than we add new ships. Our force will be shrinking during the next 15 years and reach a low point around 2029, well below the Combatant Commander’s current requirements and below the SSN Force Level requirement of 48.



By the way, that requirement of 48 SSNs was set when the *peer and near-peer threat* were considered benign. In light of adversary trends, it is reasonable to expect SSN requirements to grow not shrink.

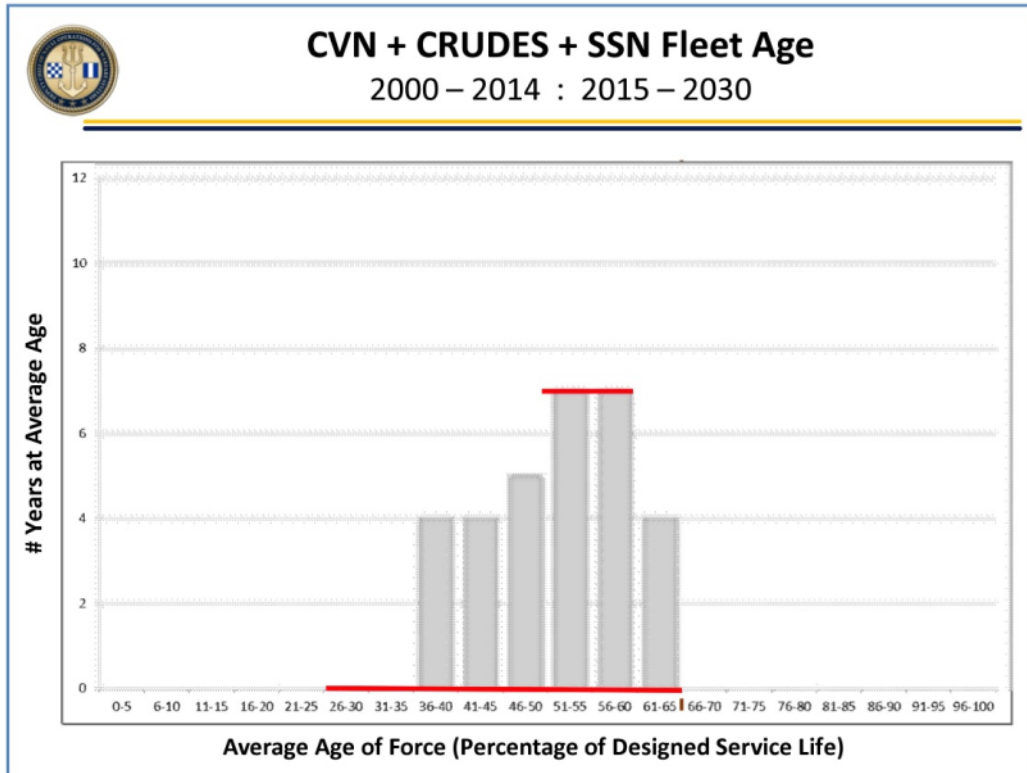

So, we can clump together Carriers and CRUDES and SSNs and see that *normal* looks like for the combatant parts of the Navy.

What about the SSBN force?

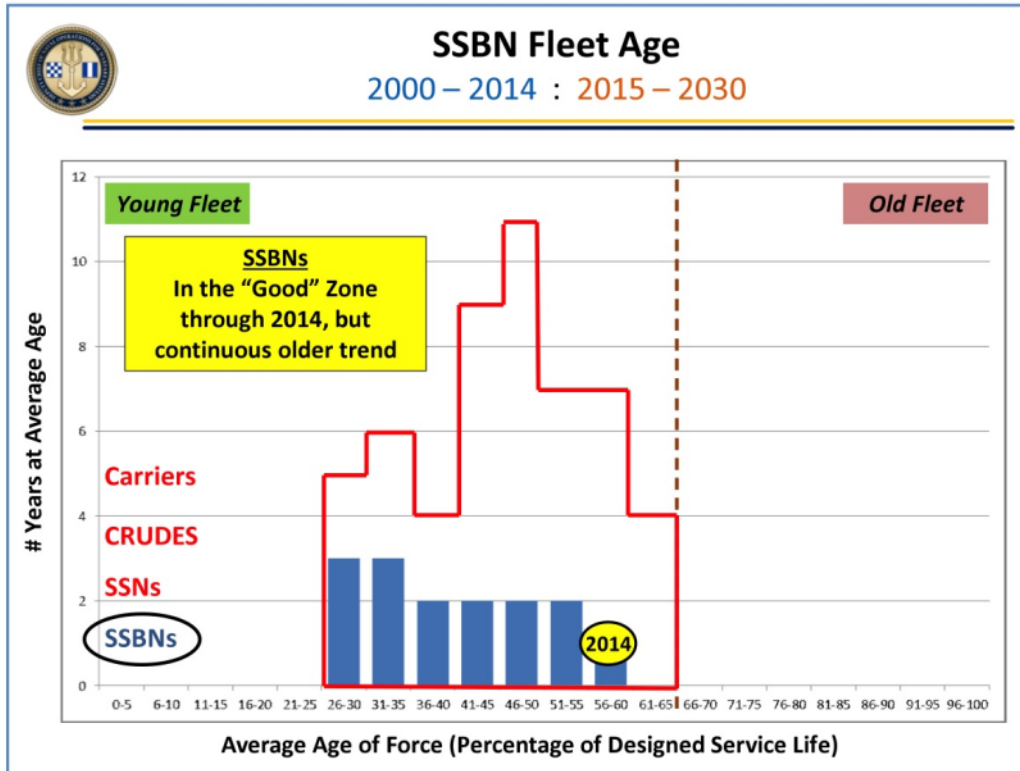

On this slide you can see that our SSBN force average age has been walking from left to right as our constant force level grows older year by year.

We are riding the Navy *norm* and in the *good zone*.



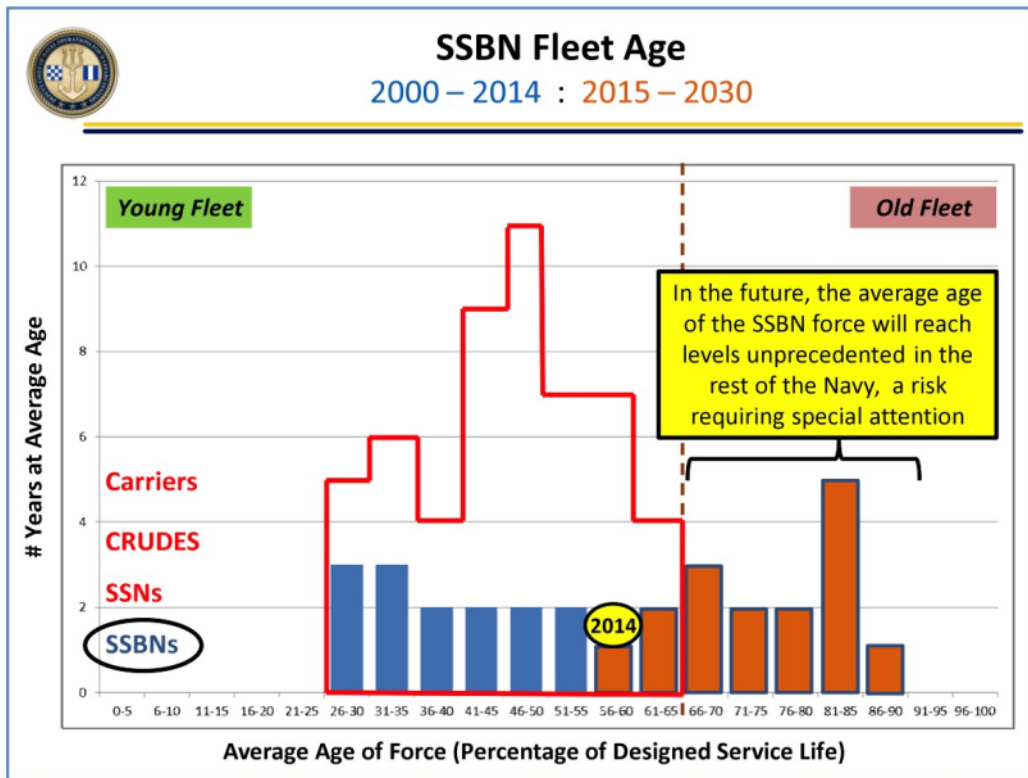

But here is the big takeaway as we move forward from 2014. In the future, we will bust through the *upper limit* as we move from 65 percent to 75 percent to 85 percent and all the way to near 90 percent.

We have never operated in this zone as a Navy.

We have no slack for introducing the new SSBN, and we have no slack in doing all we can to keep the SSBNs as they age reliable and survivable. This is going to be a task that will require attention – it is not going to happen all by itself.

Which brings us to our final question: Where is the money going to come from for the OHIO Replacement? Since we are building the first ship in 2021, that means it is showing up in full in the 2017 budget. No more talking about it being *out there in the future*. It will be here, in the room, for the 2017 budget discussions. It is time to get serious about topline relief.

Here are a couple key thoughts I emphasize in the Pentagon on this question.



Funding the OHIO Replacement SSBN

We cannot delay funding the new SSBN any further

We cannot keep diverting questions about funding the SSBN into discussions about the cost of each SSBN hull

We must have topline relief to fund the SSBN without unacceptable impacts on the Navy shipbuilding plan

- We might have a separate account
- We might have more SCN

The “One Third Rule” is not a rule and is irrelevant to new SSBN funding

- History does not support the idea of such a “rule”
- Service share percentage is neither a relevant argument for or against the proper funding of the new SSBN

Finally time to put real money in the budget for OR SSBN

First and most importantly, we cannot dodge the question by delaying the OHIO Replacement any further. We have squeezed all the blood we can from that stone and there is no more to be gained. In fact, if anything, we need to put blood back into the stone!

Second, we cannot turn our angst about funding the SSBN program into an unrealistic obsession to reduce the cost of each OHIO Replacement SSBN. We need to be as cost-conscious as possible but we have our major energies focused on the wrong fight. It is the same *wrong think* as fixating on the reduction of defense expenditures to correct a fiscal crisis due to non-defense expenditures. We need to raise this priority to the front of the line and make sure the nation understands how to resource it properly.

When the nation is called to put troops on the ground and fight two land wars in the Middle East, we don't force the Army to fund

that within a constant top line. We provide supplemental funding in the form of Overseas Contingency Operations and also increase the Army's Manpower budget, their major TOA driver. Recapitalizing our SSBN force is very much the same idea. It is an episodic national requirement that should be cast in the same light.

One difference is that this is not a surprise. You can plan ahead for this contingency. We knew this one has been coming for years if not decades ahead of time. I find it reprehensible that we are treating this like an unfortunate surprise and closing our eyes and wishing it would go away.

If we fund the OR SSBN the way we should – with relief from above Navy's topline – then we should be able to continue to procure the platforms that the rest of the Navy requires. By the way, this would include procuring our VIRGINIA-class SSNs at two per year to reduce the gap in force levels that are coming, and with the VIRGINIA Payload Module to compensate for SSGN retirement.

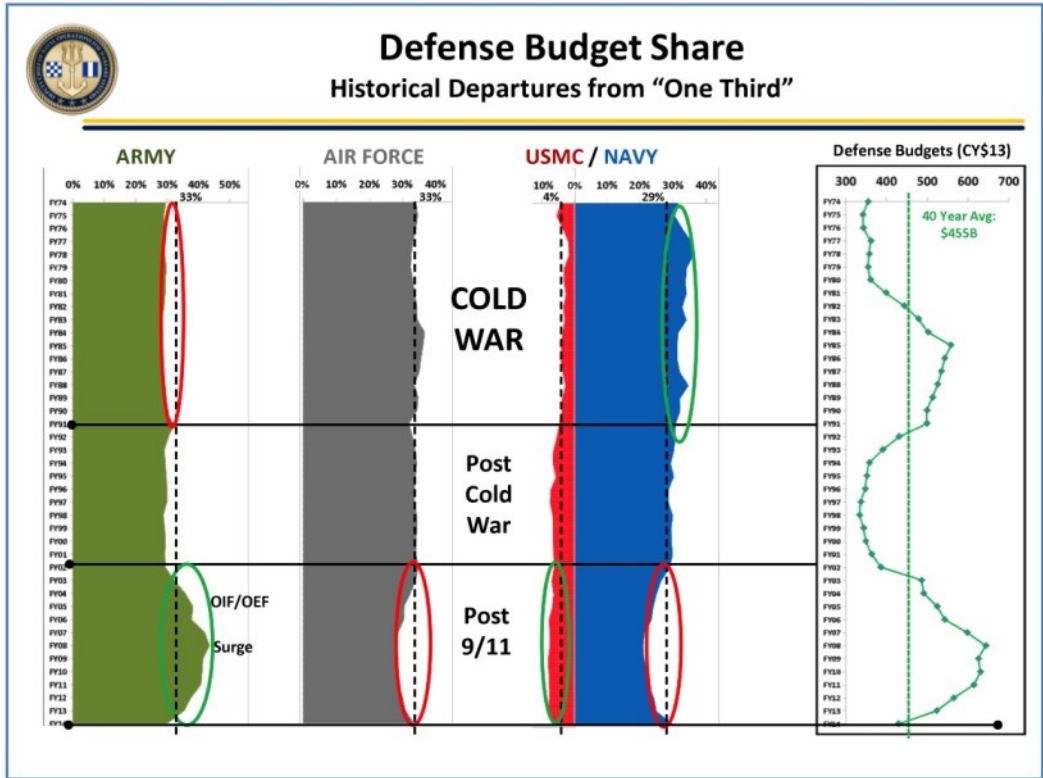

Which brings me to my final point of the morning – pushing back on the dreaded *One Third Rule*. Ah, that fearsome law of nature! That irresistible budgetary juggernaut: The “One Third Rule.”

This slide shows a 1/3 convention, but it makes clear that it may be a thumb rule but it is not a rigid, fixed law.

You can see clearly that the Army share of service expenditures has been well in excess of one third when we were fighting two land wars in the Middle East. Again, there should be no doubt in anyone’s mind that was the right thing to do. You can also see that back during the Reagan build-up the Navy had a share larger than normal. That made sense then, too.

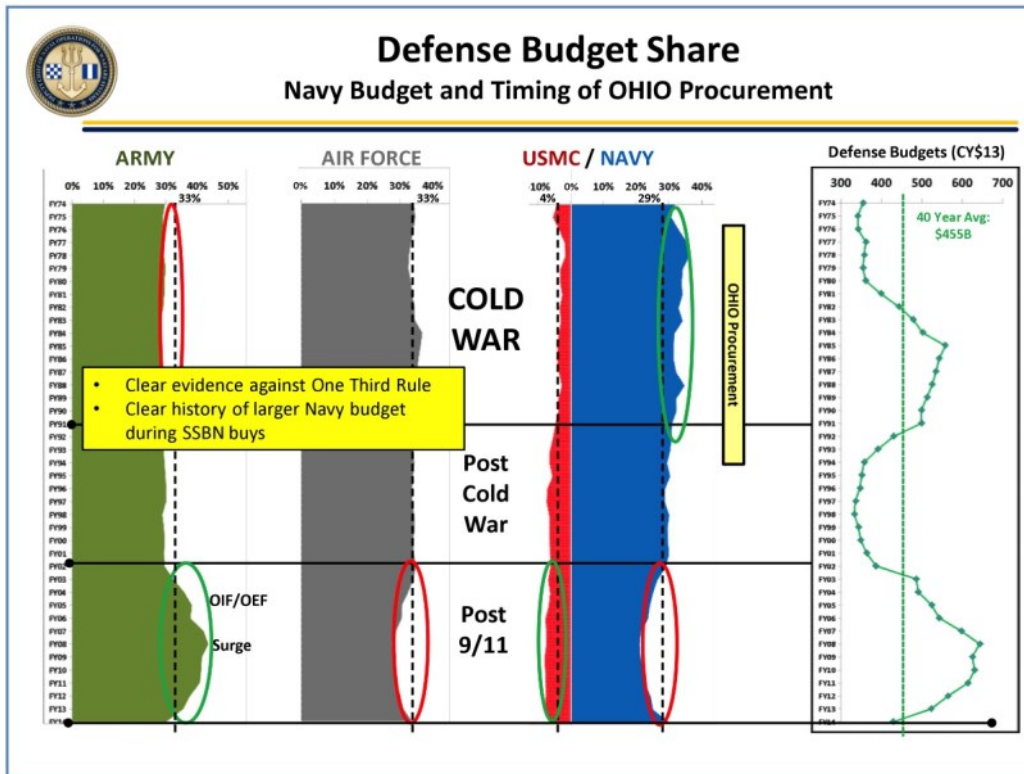

And, by the way, this same time period is when the Navy last had to recapitalize the Nation’s SSBN force.

So, if we need topline relief in the Navy for the SSBN, is it right to say “it should come from the other services”? Maybe it should. Maybe not. Maybe it should come from Medicare or interest on the debt or tax increases. There are plenty of choices about where the SSBN funding should come from. But it can’t come from the Navy shipbuilding account.

The bottom line is this – under no circumstances should Navy shipbuilding funding be denied because “the one third rule” keeps us from getting the right funding. That bogus rule should not be used to get us funding and it should not be used to keep us from getting the funding we need. If you have to use the One Third Rule to make your case, you are revealing that you don’t have a case.

We covered a lot of material this morning.

We hit on three big ideas where we all need to get aligned and do what is right and best for our country. As Secretary Work said, we are lucky to be at the forefront of influencing so many critical decisions at such a critical time for our country.

Don't flinch from your duty!



Looking Ahead at Undersea Investment Imperatives

1	<div style="background-color: #d9ead3; padding: 5px; margin-bottom: 5px;">Rapidly Changing Strategic Environment</div> <ul style="list-style-type: none"> More overtly aggressive actions by RU, CH, IR and NK US being called upon to undertake more intrusive leadership US undergoing internal debate with predictable outcome <div style="background-color: #d9ead3; padding: 5px; margin-bottom: 5px;">Implications for the Navy and the Undersea</div> <ul style="list-style-type: none"> US will depend more heavily on the Navy and Undersea Urgent need for innovation in undersea systems Increased pressure on undersea nuclear forces 	
2	<div style="background-color: #d9ead3; padding: 5px; margin-bottom: 5px;">The "Fiscal Reality" Fallacy</div> <ul style="list-style-type: none"> The flat Defense/Navy budgets are not part of the problem Even <u>zeroing</u> the Defense/Navy will not solve the fiscal problem Further Defense/Navy cuts will <u>aggravate</u> our problems <div style="background-color: #d9ead3; padding: 5px; margin-bottom: 5px;">The Urgency of Innovation</div> <ul style="list-style-type: none"> Innovate today so we can be poised to build tomorrow Cannot afford to wait for the "near death experience" UDCP and IUFS provide solid innovation guidance 	
3	<div style="background-color: #d9ead3; padding: 5px; margin-bottom: 5px;">Navy Funding and the OR SSBN</div> <ul style="list-style-type: none"> There is no "One Third Rule" – funding goes where needed SSBN force age and threat dynamics compel action Protection of Navy shipbuilding requires OR Topline relief 	



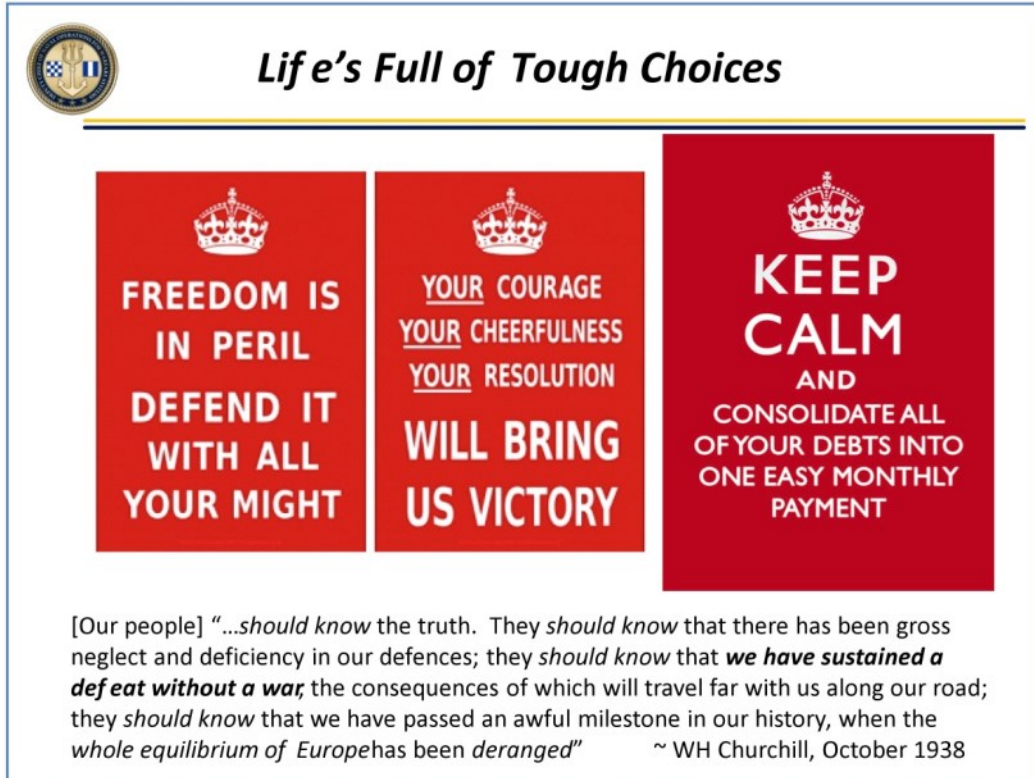

Leading up to World War Two, there was a progression of motivational posters published by the UK to rally the national will of the people.

“Freedom is in peril” came out in 1937. Time for courage and resolution came out in 1939. The final poster I show here was never published.

But I worry that our distracted national public and policymakers will be absorbed in the wrong debate during this critical period in world history. Let’s not deal with our national financial crisis using sleight of hand and budgetary gimmicks. Let’s not kid ourselves by pushing the burden onto the defense budget – only delaying and worsening the situation that results.

In conclusion, as Winston Churchill reminds us, we can’t allow our mismanagement of the debt crisis to lead us to sustaining a defeat without a war where the equilibrium of free democracies around the world becomes deranged.

I thank you for what you do to keep the United States great.



SILENT DEFENDER.

Multi-mission | Nuclear-powered | Advanced Stealth Technology

USS Minnesota (SSN 783)

HuntingtonIngalls.com



Hard Stuff Done Right™



Save the Dates

2015 HISTORY SEMINAR

15 April 2015

Nay Yard Museum, Cold War Gallery

SUBMARINE TECHNOLOGY SYMPOSIUM

12-14 May 2015

Johns Hopkins University-APL

CORPORATE MEMBER RECOGNITION DAYS

4-5 March 2015

Fairview Park Marriott, Falls Church, VA

33rd ANNUAL SYMPOSIUM

21-22 October 2015

Fairview Park Marriott, Falls Church, VA

**NAVY FORCE STRUCTURE AND
SHIPBUILDING EXCERPTS**

**MR. RONALD O'ROURKE
SPECIALIST IN NAVAL AFFAIRS**

**AUGUST 1, 2014
CONGRESSIONAL RESEARCH SERVICE**

Summary

The Navy's proposed FY2015 budget requests funding for the procurement of seven new battle force ships (i.e., ships that count against the Navy's goal for achieving and maintaining a fleet of 306 ships). The seven ships include two Virginia-class attack submarines, two DDG-51 class Aegis destroyers, and three Littoral Combat Ships (LCSs). The Navy's proposed FY2015-FY2019 five-year shipbuilding plan includes a total of 44 ships, compared to a total of 41 ships in the FY2014-FY2018 five-year shipbuilding plan.

The planned size of the Navy, the rate of Navy ship procurement, and the prospective affordability of the Navy's shipbuilding plans have been matters of concern for the congressional defense committees for the past several years. The Navy's FY2015 30-year (FY2014-FY2044) shipbuilding plan, like many previous Navy 30-year shipbuilding plans, does not include enough ships to fully support all elements of the Navy's 306-ship goal over the entire 30-year period. In particular, the Navy projects that the fleet would experience a shortfall in amphibious ships from FY2015 through FY2017, a shortfall in small surface combatants from FY2015 through FY2027, and a shortfall in attack submarines from FY2025 through FY2034.

The Navy delivered its narrative report on the FY2015 30-year shipbuilding plan to CRS (Congressional Research Service) on July 3, 2014. The Navy estimates in the report that the plan would cost an average of about \$16.7 billion per year in constant FY2014 dollars to implement. The Congressional Budget Office (CBO) is now preparing its own estimate of the cost to implement the plan;

this estimate will be made available later this year. CBO's estimates of the cost to implement past annual versions of the Navy's 30-year shipbuilding plan have been higher than the Navy's estimates. Some of the difference between CBO's estimate and the Navy's estimate, particularly in the latter years of the plan, has been due to a difference between CBO and the Navy in how to treat inflation in Navy shipbuilding.

Potential issues for Congress in reviewing the Navy's proposed FY2015 shipbuilding budget, its proposed FY2015-FY2019 five-year shipbuilding plan, and its FY2015 30-year (FY2015-FY2044) shipbuilding plan include the following:

- the Navy's proposal to defer until FY2016 a decision on whether to proceed with the mid-life nuclear refueling overhaul of the aircraft carrier George Washington (CVN-73);
- the Navy's proposal to put 11 of its 22 Aegis cruisers into some form of reduced operating status starting in FY2015, and then return them to service years from now;
- the Navy's proposal to retire all 10 of its remaining Oliver Hazard Perry (FFG-7) class frigates in FY2015;
- the Navy's proposal to modify the rules for what ships to include in the count of the number of battle force ships in the Navy;
- the potential impact on the size of the Navy of limiting DOD spending in FY2013-FY2021 to the levels set forth in the Budget Control Act of 2011, as amended;
- the appropriate future size and structure of the Navy in light of budgetary and strategic considerations; and
- the affordability of the 30-year shipbuilding plan.

Funding levels and legislative activity on individual Navy shipbuilding programs are tracked in detail in other CRS reports.

Background

Navy's Ship Force Structure Goal

January 2013 Goal for Fleet of 306 Ships

On January 31, 2013, in response to Section 1015 of the FY2013 National Defense Authorization Act (H.R. 4310/P.L. 112-239 of January 2, 2013), the Navy submitted to Congress a report presenting a goal for achieving and maintaining a fleet of 306 ships, consisting of certain types and quantities of ships. The goal for a 306-ship fleet is the result of a force structure assessment (FSA) that the Navy completed in 2012.

306-Ship Goal Reflects 2012 Strategic Guidance and Projected DOD Spending Shown in FY2013 and FY2014 Budget Submissions.

The 2012 FSA and the resulting 306-ship plan reflect the defense strategic guidance document that the Administration presented in January 2012 and the associated projected levels of Department of Defense (DOD) spending shown in the FY2013 and FY2014 budget submissions.

DOD officials have stated that if planned levels of DOD spending are reduced below what is shown in these budget submissions, the defense strategy set forth in the January 2012 strategic guidance document might need to be changed. Such a change, Navy officials have indicated, could lead to the replacement of the 306-ship plan of January 2013 with a new plan.

Goal for Fleet of 306 Ships Compared to Earlier Goals

Table 1 compares the 306-ship goal to earlier Navy ship force structure plans.



Ship type	306-ship plan of January 2013	~310-316 ship plan of March 2012	Revised 313-ship plan of September 2011	Changes to February 2006 ship plan announced through mid-2011	February 2006 Navy plan for 313-ship fleet	Early-2005 Navy plan for fleet of		2002-2004 Navy plan for 375 ship Navy ^a	2001 QDR plan for 310-ship Navy
						260-325 ships	325-ships		
Ballistic missile submarines (SSBNs)	12 ^b	12-14 ^b	12 ^b	12 ^b	14	14	14	14	14
Cruise missile submarines (SSGNs)	0 ^c	0-4 ^c	4 ^c	0 ^c	4	4	4	4	2 or 4 ^d
Attack submarines (SSNs)	48	~48	48	48	48	37	41	55	55
Aircraft carriers and destroyers	11 ^e	11 ^e	11 ^e	11 ^e	11 ^f	10	11	12	12
Cruisers	88	~90	94	94 ^g	88	67	92	104	116
Frigates	0	0	0	0	0	0	0	0	0
Littoral Combat Ships (LCSs)	52	~55	55	55	55	63	82	56	0
Amphibious ships	33	~32	33	33 ^h	31	17	24	37	36
MPF(F) ships ⁱ	0 ⁱ	0 ⁱ	0 ⁱ	0 ⁱ	12 ⁱ	14 ⁱ	20 ⁱ	0 ⁱ	0 ⁱ
Combat logistics (resupply) ships	29	~29	30	30	30	24	26	42	34
Dedicated mine warfare ships	0	0	0	0	0	0	0	26 ^k	16
Joint High Speed Vessels (JHSVs)	10 ^l	10 ^l	10 ^l	21 ^l	3	0	0	0	0
Other ^m	23	~23	16	24 ⁿ	17	10	11	25	25
Total battle force ships	306	~310-316	313	328	313	260	325	375	310 or 312

**Navy’s Five-Year and 30-Year Shipbuilding Plans
Five-Year (FY2015-FY2019) Shipbuilding Plan**

Table 2 shows the Navy’s FY2015 five-year (FY2015-FY2019) shipbuilding plan.

Table 2. Navy FY2014 Five-Year (FY2015-FY2019) Shipbuilding Plan
(Battle force ships—i.e., ships that count against 306-ship goal)

Ship type	FY15	FY16	FY17	FY18	FY19	Total
Ford (CVN-78) class aircraft carrier				1		1
Virginia (SSN-774) class attack submarine	2	2	2	2	2	10
Arleigh Burke (DDG-51) class destroyer	2	2	2	2	2	10
Littoral Combat Ships (LCS)	3	3	3	3	2	14
LHA(R) amphibious assault ship			1			1
Fleet tug (TATF)			2	1	1	4
Mobile Landing Platform (MLP)/Afloat Forward Staging Base (AFSB)			1			1
TAO(X) oiler		1		1	1	3
TOTAL	7	8	11	10	8	44

Source: FY2015 Navy budget submission.

Notes: The MLP/AFSB is a variant of the MLP with additional features permitting it to serve in the role of an AFSB. The Navy proposes to fund the TATFs and TAO(X)s through the National Defense Sealift Fund (NDSF) and the other ships through the Navy’s shipbuilding account, known formally as the Shipbuilding and Conversion, Navy (SCN) appropriation account.

Observations that can be made about the Navy’s proposed FY2015 five-year (FY2015-FY2019) shipbuilding plan include the following:

- **Total of 44 ships.** The plan includes a total of 44 ships, compared to a total of 41 ships in the FY2014-FY2018 five-year shipbuilding plan.
- **Average of 8.8 ships per year.** The plan includes an average of 8.8 battle force ships per year. The steady-state replacement rate for a fleet of 306 ships with an average service life of 35 years is about 8.7 ships per year. In light of how the average shipbuilding rate since FY1993 has been substantially below 8.7 ships per year (see Appendix D), shipbuilding supporters for some time have wanted to increase the shipbuilding rate to a steady rate of 10 or more battle force ships per year.
- **DDG-51 destroyers and Virginia-class submarines being procured under MYP arrangements.** The 10 DDG-51 destroyers to be procured in FY2013-FY2017 and the 10 Virginia-class attack submarines to be procured in FY2014-FY2018 are being procured under multiyear procurement (MYP) contracts.
- **Navy is requesting three rather than four LCSs for FY2015.** LCSs are being procured under a pair of block buy contracts covering the years FY2010-FY2015. These two contracts call for a total of four LCSs in FY2015. The Navy, however, is requesting funding for the procurement of three LCSs in FY2015. If three LCSs are funded in FY2015, one of the two LCS block buy contracts would not be fully implemented in its final year.
- **Start of LX(R) amphibious ship procurement deferred to FY2020.** The FY2015-FY2019 five-year shipbuilding plan defers the procurement of the first LX(R) amphibious ship to FY2020, compared to FY2019 in the FY2014-FY2018 plan, FY2018 in the FY2013-FY2017 plan, and FY2017 in the FY2012-FY2016 plan. In each of these five-year plans, the lead LX(R) ship was scheduled one year beyond the end of the five-year period.
- **MLP/AFSB ship added to FY2017.** The FY2015-FY2019 five-year shipbuilding plan adds an MLP/AFSB (Mobile Landing Platform/Afloat Forward Staging Base) ship in FY2017. This ship, not previously planned, would likely be built by General Dynamics/National Steel and Shipbuilding Company (GD/NASSCO), the builder of prior MLP/AFSB ships. In addition

to providing a platform that would help the Navy meet certain operational needs, adding this ship to the shipbuilding plan might help the Navy ensure strong competition for two other Navy ship programs—the TAO(X) oiler program, the first ship of which is to be procured in FY2016, and the LX(R) amphibious ship program, the first ship of which is to be procured in FY2020.

30-Year (FY2015-FY2044) Shipbuilding Plan

Table 3 shows the Navy’s FY2015 30-year (FY2015-FY2044) shipbuilding plan.

Table 3. Navy FY2015 30-Year (FY2015-FY2044) Shipbuilding Plan

FY	CVN	LSC	SSC	SSN	SSBN	AWS	CLF	Supt	Total
15		2	3	3					7
16		2	3	2			1		8
17		2	3	2		1		3	11
18	1	2	3	2			1	1	10
19		2	2	2			1	1	8
20		2	3	2		1	1	2	11
21		2	3	1	1		1		8
22	2	3	2			1	1	2	11
23	1	2	3	1			1	3	11
24		2	3	2	1	2	1	2	13
25		2	3	1			1	1	8
26		2		2	1	1	1		7
27		2		1	1		1		5
28	1	2		2	1	1	1	1	10
29		2		1	1	1	1	1	7
30		2	1	2	1	1	1	2	10
31		2		1	1	1	1	2	8
32		2	1	2	1	2	1	3	12
33	1	2		1	1	1	1	2	9
34		2	1	2	1	1		2	9
35		2	1	1	1				5
36		2		2		1			5
37		2	4	1					7
38	1	3	4	2					10
39		3	4	1					8
40		3	4	2		2			11
41		3	4	1					8
42		3	4	2		1			10
43	1	2	3	1			1		9
44		2	2	2		2			8

Source: FY2015 30-year (FY2015-FY2044) shipbuilding plan.



Key: **FY** = Fiscal Year; **CVN** = aircraft carriers; **LSC** = surface combatants (i.e., cruisers and destroyers); **SSC** = small surface combatants (i.e., Littoral Combat Ships [LCSs]); **SSN** = attack submarines; **SSGN** = cruise missile submarines; **SSBN** = ballistic missile submarines; **AWS** = amphibious warfare ships; **CLF** = combat logistics force (i.e., resupply) ships; Supt = support ships.

In devising a 30-year shipbuilding plan to move the Navy toward its ship force-structure goal, key assumptions and planning factors include but are not limited to the following:

- ship service lives;
- estimated ship procurement costs;
- projected shipbuilding funding levels; and
- industrial-base considerations.

Navy's Projected Force Levels Under 30-Year Shipbuilding Plan

Table 4 shows the Navy's projection of ship force levels for FY2015-FY2044 that would result from implementing the FY2015 30-year (FY2015-FY2044) shipbuilding plan shown in **Table 3**.

As part of its FY2015 budget submission, the Navy is proposing to modify the rules for what ships to include in the count of the number of battle force ships in the Navy. In its FY2015 budget submission, the Navy has presented figures for projected Navy ship force levels using both the existing rules and the proposed modified rules. **Table 4** and **Table 6** show figures using both the existing rules and the proposed modified rules.

Table 4. Projected Force Levels Resulting from FY2015 30-Year (FY2015-FY2044) Shipbuilding Plan

Where two figures are shown, the first is the figure using existing rules for counting battle force ships, and the second is the figure using the Navy’s proposed modified rules for counting battle force ships.

	CVN	LSC	SSC	SSN	SSGN	SSBN	AWS	CLF	Supt	Total
306 ship plan	11	88	52	48	0	12	33	29	33	306
FY15	10	85	19/26	54	4	14	30	29	29/32	274/284
FY16	11	88	23/30	53	4	14	31	29	27/30	280/290
FY17	11	90	27/34	50	4	14	32	29	29/32	286/296
FY18	11	91	31/38	52	4	14	33	29	29/32	295/304
FY19	11	93	35/40	51	4	14	33	29	31/34	301/309
FY20	11	95	36/37	49	4	14	33	29	33/36	304/308
FY21	11	96	36/33	49	4	14	33	29	32/35	304
FY22	11	97	38/36	48	4	14	33	29	32/35	306/307
FY23	12	98	39	49	4	14	33	29	33/36	311/314
FY24	12	98	41/40	48	4	14	34	29	33/36	313/315
FY25	11	98	43	47	4	14	34	29	34/37	314/317
FY26	11	97	46	45	2	14	36	29	34/37	314/317
FY27	11	99	49	44	1	13	35	29	34/37	315/318
FY28	11	100	52	41	0	13	36	29	34/37	316/319
FY29	11	98	52	41	0	12	35	29	34/37	312/315
FY30	11	95	52	41	0	11	35	29	34/37	308/311
FY31	11	91	52	43	0	11	34	29	34/36	305/307
FY32	11	89	52	43	0	10	34	29	35/37	303/305
FY33	11	88	52	45	0	10	35	29	35/37	305/307
FY34	11	86	52	46	0	10	34	29	35/37	303/305
FY35	11	87	52	48	0	10	32	29	35/37	304/306
FY36	11	88	52	49	0	10	32	29	35	306
FY37	11	90	52	51	0	10	33	29	34	310
FY38	11	91	52	50	0	10	33	29	35	311
FY39	11	92	52	51	0	10	33	29	34	312
FY40	10	90	52	51	0	10	32	29	34	308
FY41	10	89	52	51	0	11	33	29	34	309
FY42	10	87	52	52	0	12	32	29	34	308
FY43	10	84	52	52	0	12	31	29	34	304
FY44	10	83	52	52	0	12	31	29	34	303

Source: FY2015 30-year (FY2015-FY2044) shipbuilding plan.

Note: Figures for support ships include five JHSVs transferred from the Army to the Navy and operated by the Navy primarily for the performance of Army missions.



Key: **FY** = Fiscal Year; **CVN** = aircraft carriers; **LSC** = surface combatants (i.e., cruisers and destroyers); **SSC** = small surface combatants (i.e., frigates, Littoral Combat Ships [LCSs], and mine warfare ships); **SSN** = attack submarines; **SSGN** = cruise missile submarines; **SSBN** = ballistic missile submarines; **AWS** = amphibious warfare ships; **CLF** = combat logistics force (i.e., resupply) ships; **Supt** = support ships.

Observations that can be made about the Navy’s FY2015 30-year (FY2015-FY2044) shipbuilding plan and resulting projected force levels included the following:

- **Total of 264 ships; average of about 8.8 per year.** The plan includes a total of 264 ships to be procured, two less than the number in the FY2014 30-year (FY2014-FY2043) shipbuilding plan. The total of 264 ships equates to an average of about 8.8 ships per year, which is slightly higher than the approximate average procurement rate (sometimes called the steady-state replacement rate) of about 8.7 ships per year that would be needed over the long run to achieve and maintain a fleet of 306 ships, assuming an average life of 35 years for Navy ships.
- **Proposed modified counting rules affect small surface combatants and support ships.** As can be seen in Table 4, the Navy’s proposed modified rules for what ships to include in the count of the number of battle force ships (see “Proposal to Modify What Ships Are Included in the Count of Battle Force Ships” in “Oversight Issues for Congress for FY2015”) would affect the reported figures for small surface combatants during the period FY2015-FY2024 and the reported figures for support ships during the period FY2015-FY2035.
- **Eleven cruisers proposed for some form of reduced operating status included in count.** As part of its FY2015 budget submission, the Navy is proposing to put 11 of its 22 Aegis cruisers into some form of reduced operating status starting in FY2015, and then return them to service years from now. The 11 cruisers proposed for some form of reduced operating status are

included in the count of battle force ships shown in Table 4 and Table 6 during the years that they are in reduced operating status.

- **Projected shortfalls in amphibious ships, small surface combatants, and attack submarines.** The FY2015 30-year shipbuilding plan, like many previous Navy 30-year shipbuilding plans, does not include enough ships to fully support all elements of the Navy's 306-ship goal over the entire 30-year period. In particular, the Navy projects that the fleet would experience a shortfall in amphibious ships from FY2015 through FY2017, a shortfall in small surface combatants from FY2015 through FY2027, and a shortfall in attack submarines from FY2025 through FY2034.

- **Ballistic missile submarine force to be reduced temporarily to 10 boats.** As a result of a decision in the FY2013 budget to defer the scheduled procurement of the first Ohio replacement (SSBN[X]) ballistic missile submarine by two years, from FY2019 to FY2021, the ballistic missile submarine force is projected to drop to a total of 10 or 11 boats—one or two boats below the 12-boat SSBN force-level goal—during the period FY2029-FY2041. The Navy says this reduction is acceptable for meeting current strategic nuclear deterrence mission requirements, because none of the 10 or 11 boats during these years will be encumbered by long-term maintenance.

Appropriate Future Size and Structure of Navy in Light of Strategic and Budgetary Changes

Another potential oversight issue for Congress concerns the appropriate future size and structure of the Navy. Changes in strategic and budgetary circumstances have led to a broad debate over the future size and structure of the military, including the Navy. Changes in strategic circumstances include, among other things, the end of U.S. combat operations in Iraq, the winding down of U.S. combat operations in Afghanistan, China's military (including naval) modernization effort, maritime territorial

disputes involving China, and Russia's seizure and annexation of Crimea.

On January 5, 2012, the Administration announced that, in light of the end of U.S. combat operations in Iraq, the winding down of such operations in Afghanistan, and developments in the Asia-Pacific region, U.S. defense strategy in coming years will include a stronger focus on the Asia-Pacific region. Since the Asia-Pacific region is primarily a maritime and aerospace theater for the DOD, this shift in strategic focus is expected by many observers to result in a shift in the allocation of DOD resources toward the Navy and Air Force. DOD officials have indicated that if planned levels of DOD spending in future years are reduced as a result of the BCA or other legislative action, they will seek to protect efforts supporting a stronger focus on the Asia-Pacific region.

The Navy's current goal for a fleet of 306 ships reflects a number of judgments and planning factors (some of which the Navy receives from the Office of the Secretary of Defense), including but not limited to the following:

- U.S. interests and the U.S. role in the world, and the U.S. military strategy for supporting those interests and that role;
- current and projected Navy missions in support of U.S. military strategy, including both wartime operations and day-to-day forward-deployed operations;
- current and projected capabilities of potential adversaries, including their anti-access/area-denial (A2/AD) capabilities;
- regional combatant commander (COCOM) requests for forward-deployed Navy forces;
- the individual and networked capabilities of current and future Navy ships and aircraft;
- basing arrangements for Navy ships, including numbers and locations of ships homeported in foreign countries;
- maintenance and deployment cycles for Navy ships; and
- fiscal constraints.

With regard to the fourth point above, Navy officials testified in March 2014 that a Navy of 450 ships would be required to fully meet COCOM requests for forward-deployed Navy forces. The difference between a fleet of 450 ships and the current goal for a fleet of 306 ships can be viewed as one measure of the operational risk associated with the goal of a fleet of 306 ships. A goal for a fleet of 450 ships might be viewed as a fiscally unconstrained goal.

Actions by China starting in November 2013 that appear aimed at achieving a greater degree of control over China's near-seas region, followed by Russia's seizure and annexation of Crimea in March 2014, have led to a discussion among observers about whether we are currently shifting from the familiar post-Cold War era of the last 20 to 25 years to a new and different strategic era characterized by, among other things, renewed great power competition and challenges to key aspects of the U.S.-led international order that has operated since World War II. Some observers in this discussion have used the term "post-Crimea era" or "post-Crimea world."

A shift in strategic eras can lead to a reassessment of assumptions and frameworks of analysis relating to defense funding levels, strategy, missions, plans, and programs. The shift from the Cold War to the post-Cold War era led to such a reassessment in the early 1990s. This reassessment led to numerous substantial changes in U.S. defense plans and programs. Numerous other defense programs were changed to lesser degrees or were not changed.

A shift from the post-Cold War era to a new strategic era could lead to a new reassessment of assumptions and frameworks of analysis relating to defense funding levels, strategy, missions, plans, and programs. There are some indications that elements of such a reassessment may have begun. For example, some observers, including General Philip Breedlove, the Commander of U.S. European Command, have raised the issue of whether the United States should consider halting the U.S. military drawdown in Europe, so as to respond to a more assertive Russia.

For additional discussion of the relationship between U.S. strategy and the size and structure of U.S. naval forces that can form part of the context for assessing the 30-year shipbuilding plan, see **Appendix C**.

Some study groups have made their own proposals for Navy ship force structure that reflect their own perspectives on the points listed above (particularly the first three and the final one) shows some of these proposals. For purposes of comparison, **Table 5** also shows the Navy's 306-ship goal of January 2013.

TABLE 5 Recent Study Group Proposals for Navy Ship Force Structure

Ship type	Navy's 306-ship goal of January 2013	Project on Defense Alternatives (PDA) (November 2012)	Heritage Foundation (April 2011)	Cato Institute (September 2010) ^a	Independent Panel Assessment of 2010 QDR (July 2010)	Sustainable Defense Task Force (June 2010)	Center for a New American Security (CNAS) (November 2008)	Center for Strategic and Budgetary Assessments (CSBA) (2008) ^b
<i>Submarines</i>								
SSBN	12	7	14 ^c	6	14	7	14	12
SSGN	0	6-7	4	0	4	4	0	2
SSN	48	42	55	40	55	37	40	41
<i>Aircraft carriers</i>								
CVN	11	9	11	8	11	9	8	11
CVE	0	0	0	0	0	0	0	4
<i>Surface combatants</i>								
Cruiser	88	72-74	88	22 65	n/a	85	18	14
De- stroyer					n/a		56	73
Frigate	0	2-7 ⁱ	28 ^d	14 4	n/a	0	0	9 ^e
LCS	52	12 ^j			n/a	25	48	55
SSC	0	1	0	0	n/a	0	40	0 ^f
<i>Amphibious and Maritime Prepositioning Force (Future)(MPF[F]) ships</i>								
Amphibious ships	33	≥ 23	37	23	n/a	27	36	33
MPF(F) ships	0	n/a	0	0	n/a	n/a	0	3 ^g
LSD station ships	0	0	0	0	0	0	0	7 ^h
<i>Other: Mine warfare (MIW) ships; Combat Logistics Force (CLF) ships (i.e. at-sea resupply ships), and support ships</i>								
MIW	0	14 ^j	14	11	0	0	0	0
CLF ships	29	n/a	33	21	n/a	36	40	31
Support ships	33	n/a	25	27	n/a			31
TOTAL battle force ships	306	230	309	241	346	230	300	326ⁱ

A potential key question for Congress concerns whether the U.S. Navy in coming years will be large enough to adequately counter improved Chinese maritime A2/AD forces while also adequately performing other missions of interest to U.S. policy makers around the world. Some observers are concerned that a combination of growing Chinese naval capabilities and budget-driven reductions in the size of the U.S. Navy could encourage Chinese military overconfidence and demoralize U.S. allies and partners in the Pacific, and thereby make it harder for the United States to defend its interests in the region. Potential oversight questions for Congress include the following:

- Under the Administration’s plans, will the Navy in coming years be large enough to adequately counter improved Chinese maritime A2/AD forces while also adequately performing other missions of interest to U.S. policy makers around the world?
- What might be the political and security implications in the Asia-Pacific region of a combination of growing Chinese naval capabilities and budget-driven reductions in the size of the U.S. Navy?
- If the Navy is reduced in size and priority is given to maintaining Navy forces in the Pacific, what will be the impact on Navy force levels in other parts of the world, such as the Persian Gulf/Indian Ocean region or the Mediterranean Sea, and consequently on the Navy’s ability to adequately perform its missions in those parts of the world?
- To what extent could the operational impacts of a reduction in Navy ship numbers be mitigated through increased use of forward homeporting, multiple crewing, and long-duration deployments with crew rotation (i.e., “Sea Swap”)? How feasible are these options, and what would be their potential costs and benefits?
- Particularly in a situation of constrained DOD resources, if enough funding is allocated to the Navy to permit the

Navy in coming years to maintain a fleet of 306 ships including 11 aircraft carriers, how much would other DOD programs need to be reduced, and what would be the operational implications of those program reductions in terms of DOD's overall ability to counter improved Chinese military forces and perform other missions?

Affordability of 30-Year Shipbuilding Plan

Another potential oversight issue for Congress concerns the prospective affordability of the Navy's 30-year shipbuilding plan. In assessing the prospective affordability of the 30-year plan, key factors that Congress may consider include estimated ship procurement costs and future shipbuilding funding levels. Each of these is discussed below.

Estimated Ship Procurement Costs

If one or more Navy ship designs turn out to be more expensive to build than the Navy estimates, then the projected funding levels shown in the 30-year shipbuilding plan will not be sufficient to procure all the ships shown in the plan. Ship designs that can be viewed as posing a risk of being more expensive to build than the Navy estimates include Gerald R. Ford (CVN-78) class aircraft carriers, Ohio-replacement (SSBNX) class ballistic missile submarines, the Flight III version of the DDG-51 destroyer, the TAO(X) oiler, and the LX(R) amphibious ship.

In recent years, the Congressional Budget Office (CBO) has estimated that certain Navy ships would be more expensive to procure than the Navy estimates, and consequently that the Navy's 30-year shipbuilding plan would cost more to implement than the Navy has estimated. In its October 2013 report on the cost of the FY2014 30-year shipbuilding plan, the CBO estimated that the plan would cost an average of \$19.3 billion per year in constant FY2013 dollars to implement, or about 15% more than the Navy estimated. CBO's estimate is about 6% higher than the Navy's estimate for the first 10 years of the plan, about 14% higher than the Navy's estimate for the second 10 years of the plan, and about

26% higher than the Navy’s estimate for the final 10 years of the plan. Some of the difference between CBO’s estimate and the Navy’s estimate, particularly in the latter years of the plan, is due to a difference between CBO and the Navy in how to treat inflation in Navy shipbuilding.

The Navy delivered its narrative report on the FY2015 30-year shipbuilding plan to CRS on July 3, 2014. The Navy estimates in the report that the plan would cost an average of about \$16.7 billion per year in constant FY2014 dollars to implement. The Congressional Budget Office (CBO) is now preparing its own estimate of the cost to implement the plan; this estimate will be made available later this year. CBO’s estimates of the cost to implement past annual versions of the Navy’s 30-year shipbuilding plan have been higher than the Navy’s estimates. Table 6 summarizes the Navy and CBO estimates of the FY2014 and FY2015 30-year shipbuilding plans.

Table 6. Navy and CBO Estimates of Cost of FY2014 and FY2015 30-Year Shipbuilding Plans

Funding for new-construction ships, in billions of constant FY2013 or FY2014 dollars

	First 10 years of the plan	Middle 10 years of the plan	Final 10 years of the plan	Entire 30 years of the plan
FY2014 30-year (FY2014-FY2043) plan (in constant FY2013 dollars)				
Navy estimate	15.4	19.8	15.2	16.8
CBO estimate	16.3	22.6	19.1	19.3
% difference between Navy and CBO estimates	6%	14%	26%	15%
FY2015 30-year (FY2015-FY2044) plan (in constant FY2014 dollars)				
Navy estimate	~15.7	~19.7	~14.6	~16.7
CBO estimate		Not yet available—CBO is preparing its estimate		
% difference between Navy and CBO estimates		Not yet available—CBO is preparing its estimate		

Future Shipbuilding Funding Levels

It has been known for some time that implementing the 30-year shipbuilding plan would require shipbuilding budgets in coming years that are considerably greater than those of recent years, and that funding requirements for the Ohio-replacement (SSBN[X]) ballistic missile submarine program will put particular pressure on the shipbuilding budget during the middle years of the 30-year plan. The Navy's report on the FY2015 30-year plan states:

Beginning in FY2020 and running through the end of the 30-year plan horizon, the plan requires an average annual investment of about \$17.2B [billion] (FY14\$) [i.e., in constant FY2014 dollars] to finance, which is ~\$4B/year more than our historical average annual investment of ~\$13B/yr. In particular, for the period while we are procuring the OHIO Replacement (OR) SSBN (essentially FY[20]25-FY[20]34), the Navy will have to provide an average of \$19.7B annually with the peak year in FY[20]32 at slightly more than \$24B. Even if the OHIO Replacement Program (ORP) is removed from the [required] resource total [by funding the program through a different part of the defense budget], the average funding required beginning in FY2020 is ~\$14-15B/yr to build the FSA [Force Structure Assessment] force [i.e., the planned 306-ship fleet]....

While the force structure presented [in this report] describes a battle force that meets the requirements of the National Security Strategy and the 2014 QDR [Quadrennial Defense Review]; it requires funding at an unsustainable level, particularly between FY[20]25 and FY[20]34... The average cost of this plan during the period in which the DON [Department of the Navy] is procuring OR SSBN[s] (~\$19.7B/year [during] FY2025-[FY]2034) cannot be accommodated by the Navy from existing resources—particularly if DOD is required to be funded at the BCA [Budget Control Act] levels....

The DON can only afford the SSBN procurement costs with significant increases in our [budget] top-line or by having the

SSBN funded from sources that do not result in any reductions to the DON's current resourcing level....

If the DON is unable to sustain the average annual shipbuilding budgets of \$19.7 billion over the course of the mid-term planning period, which is unlikely to be the case, the battle force will fall far short of meeting the QDR requirements.

In assessing the Navy's ability to reach the higher annual shipbuilding funding levels described above, one perspective is to note that doing so would require the shipbuilding budget to be increased by 30% to 50% from levels in recent years. In a context of constraints on defense spending and competing demands for defense dollars, this perspective can make the goal of increasing the shipbuilding budget to these levels appear daunting.

Another perspective is to note that the additional annual funding needed (roughly \$4 billion to \$6.7 billion) equates to roughly 0.8% to 1.3% of a defense budget of \$521 billion per year (the Budget Control Act figure for defense spending FY2015). Some observers, noting the U.S. strategic rebalancing toward the Asia-Pacific region, have advocated shifting a greater share of the DOD budget to the Navy and Air Force, on the grounds that the Asia-Pacific region is primarily a maritime and aerospace theater for DOD. In discussing the idea of shifting a greater share of the DOD budget to the Navy and Air Force, some of these observers refer to breaking the so-called "one-third, one-third, one-third" division of resources among the three military departments—a shorthand term sometimes used to refer to the more-or-less stable division of resources between the three military departments that existed for the three decades between the end of U.S. participation in the Vietnam War in 1973 and the start of the Iraq War in 2003. In a context of breaking the "one-third, one-third, one-third" allocation with an aim of better aligning defense spending with the strategic rebalancing, shifting 0.8% to 1.3% of the defense budget into the Navy's shipbuilding account would appear to be quite feasible.

More broadly, if defense spending were to remain constrained to the revised cap levels in the Budget Control Act, then fully funding the Department of the Navy's total budget at the levels

shown in the current Future Years Defense Plan (FYDP) would require increasing the Department of the Navy's share of the non-Defense-Wide part of the DOD budget to about 41%, compared to about 36% in the FY2014 budget and an average of about 37% for the three-decade period between the Vietnam and Iraq wars. While shifting 4% or 5% of DOD's budget to the Department of the Navy would be a more ambitious reallocation than shifting 0.8% to 1.3% of the DOD budget to the Navy's shipbuilding account, similarly large reallocations have occurred in the past.

Appendix C. U.S. Strategy and the Size and Structure of U.S. Naval Forces

This appendix presents some observations on the relationship between U.S. strategy and the size and structure of U.S. naval forces that can form part of the context for assessing Navy force structure goals and shipbuilding plans.

Strategic considerations that can be considered in assessing Navy force structure goals and shipbuilding plans include, among other things, the U.S. strategic rebalancing toward the Asia-Pacific region, China's modernization of its maritime military capabilities, and requests from U.S. regional combatant commanders (COCOMs) for forward-deployed U.S. naval forces that the Navy has testified would require a Navy of about 450 ships to fully meet.

More broadly, from a strategic perspective it can be noted that that U.S. naval forces, while not inexpensive, give the United States the ability to convert the world's oceans—a global commons that covers more than two-thirds of the planet's surface—into a medium of maneuver and operations for projecting U.S. power ashore and otherwise defending U.S. interests around the world. The ability to use the world's oceans in this manner—and to deny other countries the use of the world's oceans for taking actions against U.S. interests—constitutes an immense asymmetric advantage for the United States. This point would be less important if less of the world were covered by water, or if the oceans were carved into territorial blocks, like the land. Most of the world, however, is covered by water, and most of those waters

are international waters, where naval forces can operate freely. The point, consequently, is not that U.S. naval forces are intrinsically special or privileged—it is that they have a certain value simply as a consequence of the physical and legal organization of the planet.

An additional point that can be noted in relating U.S. naval forces to U.S. national strategy is that most of the world's people, resources, and economic activity are located not in the Western Hemisphere, but in the other hemisphere, particularly Eurasia. In response to this basic feature of world geography, U.S. policymakers for the last several decades have chosen to pursue, as a key element of U.S. national strategy, a goal of preventing the emergence of a regional hegemon in one part of Eurasia or another, on the grounds that such a hegemon could represent a concentration of power strong enough to threaten core U.S. interests by, for example, denying the United States access to some of the other hemisphere's resources and economic activity. Although U.S. policymakers do not often state this key national strategic goal explicitly in public, U.S. military operations in recent decades—both wartime operations and day-to-day operations—have been carried out in no small part in support of this key goal.

The U.S. goal of preventing the emergence of a regional hegemon in one part of Eurasia or another is a major reason why the U.S. military is structured with force elements that enable it to cross broad expanses of ocean and air space and then conduct sustained, large-scale military operations upon arrival. Force elements associated with this goal include, among other things, an Air Force with significant numbers of long-range bombers, long-range surveillance aircraft, long-range airlift aircraft, and aerial refueling tankers, and a Navy with significant numbers aircraft carriers, nuclear-powered attack submarines, large surface combatants, large amphibious ships, and underway replenishment ships.

The United States is the only country in the world that designs its military to cross broad expanses of ocean and air space and then conduct sustained, large-scale military operations upon

arrival. The other countries in the Western Hemisphere do not design their forces to do this because they cannot afford to, and because the United States is, in effect, doing it for them. Countries in the other hemisphere do not design their forces to do this for the very basic reason that they are already in the other hemisphere, and consequently instead spend their defense money on forces that are tailored largely for influencing events in their own local region.

The fact that the United States designs its military to do something that other countries do not design their forces to do—cross broad expanses of ocean and air space and then conduct sustained, large-scale military operations upon arrival—can be important to keep in mind when comparing the U.S. military to the militaries of other nations. For example, in observing that the U.S. Navy has 11 aircraft carriers while other countries have no more than one or two, it can be noted other countries do not need a significant number of aircraft carriers because, unlike the United States, they are not designing their forces to cross broad expanses of ocean and air space and then conduct sustained, large-scale military operations upon arrival.

As another example, it is sometimes noted, in assessing the adequacy of U.S. naval forces, that U.S. naval forces are equal in tonnage to the next dozen or more navies combined, and that most of those next dozen or more navies are the navies of U.S. allies. Those other fleets, however, are mostly of Eurasian countries, which do not design their forces to cross to the other side of the world and then conduct sustained, large-scale military operations upon arrival. The fact that the U.S. Navy is much bigger than allied navies does not necessarily prove that U.S. naval forces are either sufficient or excessive; it simply reflects the differing and generally more limited needs that U.S. allies have for naval forces. (It might also reflect an underinvestment by some of those allies to meet even their more limited naval needs.)

Countries have differing needs for naval and other military forces. The United States, as a country located in the Western Hemisphere with a goal of preventing the emergence of a regional hegemon in one part of Eurasia or another, has defined a need for

naval and other military forces that is quite different from the needs of allies that are located in Eurasia. The sufficiency of U.S. naval and other military forces consequently is best assessed not through comparison to the militaries of other countries, but against U.S. strategic goals.



URANIUM ENRICHMENT AND THE NUCLEAR FUEL CYCLE

*by VADM Paul Sullivan, USN, Ret.
and Mr. John Welch*

INTRODUCTION

The nuclear Submarine Force counts on reliable operation of our propulsion plants at all times, and we rely on the performance of the fuel elements in our reactors without question. But long before the reactor fueling occurs, there is significant science, engineering, and precision production work that must take place in order to produce reliable, safe fuel. The process of getting the uranium out of the ground, converting it into a form that can be enriched, processing it through the enrichment plant, and fabricating the enriched uranium into reactor fuel is unforgiving, time consuming, and expensive. This paper is a *survey level* summary of the process of producing reactor fuel, with emphasis on the most difficult phase of the process—enrichment by isotope separation. Note—this paper is applicable to the generic nuclear fuel cycle, and is not intended to represent any specifics that apply to defense purposes.

THE NUCLEAR FUEL CYCLE

The basic nuclear fuel cycle is depicted in *Figure 1*. A step-by-step discussion illustrates the unique nature of each basic process. The entire fuel cycle is heavily regulated by the Nuclear Regulatory Commission, the Environmental Protection Agency, the Department of Energy, and state and local authorities.

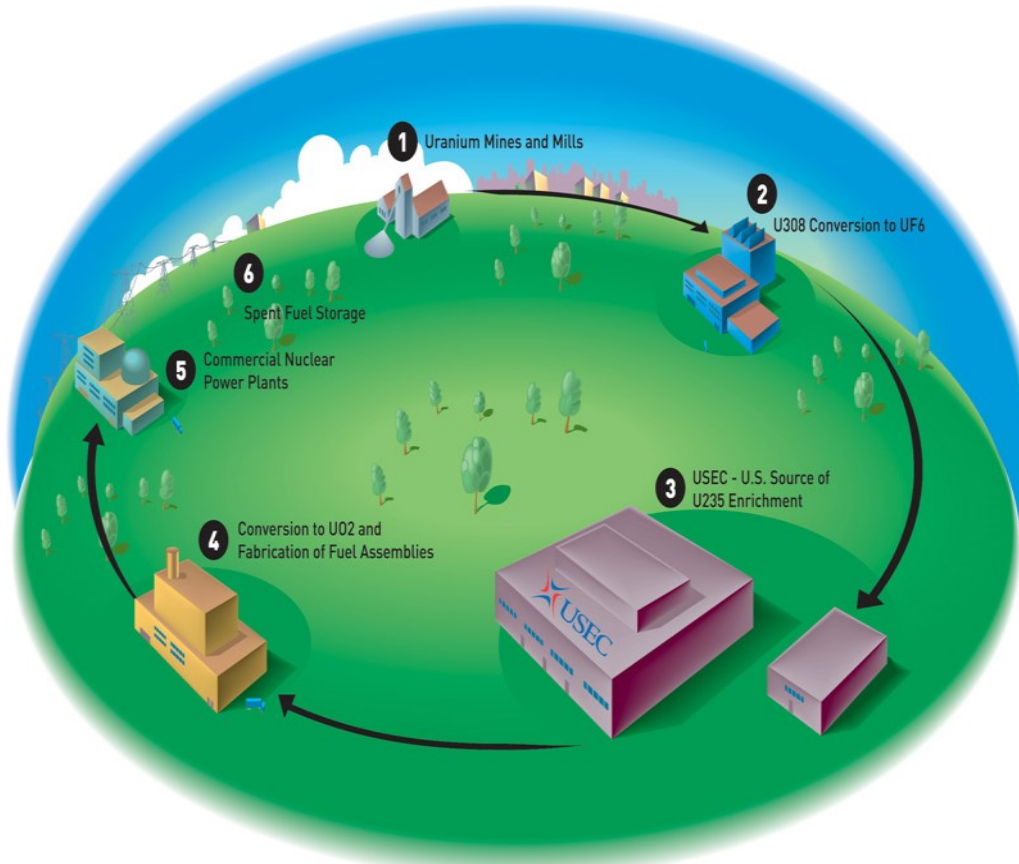

Figure 1 – The Nuclear Fuel Cycle (USEC)

1. Uranium Mines and Mills – Uranium ore is mined in various locations around the world, with most recent mining activity concentrated in areas where the deposits are richest. Natural uranium ore occurs as U_3O_8 and it has, by weight, 0.711 percent U^{235} . The busiest mining currently underway is in Kazakhstan, Australia, and Canada, which account for about 64% of the uranium mined, with other nations mining at low rates. Raw ore is useless without processing. The milling operation takes care of this by grinding the uranium oxide into a powder, the familiar *yellow cake*, which is then shipped to the conversion facility.

2. U_3O_8 Conversion to UF_6 – Early researchers had to find a chemical compound of uranium that would facilitate the enrichment process. Uranium Hexafluoride is such a chemical. At room temperature, UF_6 is a solid, but when heated



under vacuum, it sublimates to gaseous state, a form that adapts well to the current enrichment processes. *Figure 2* illustrates the advantages of uranium hexafluoride. Conversion plants chemically convert the yellow cake uranium oxide into uranium hexafluoride. In the United States, the converter is Honeywell, at their Metropolis, Illinois plant.

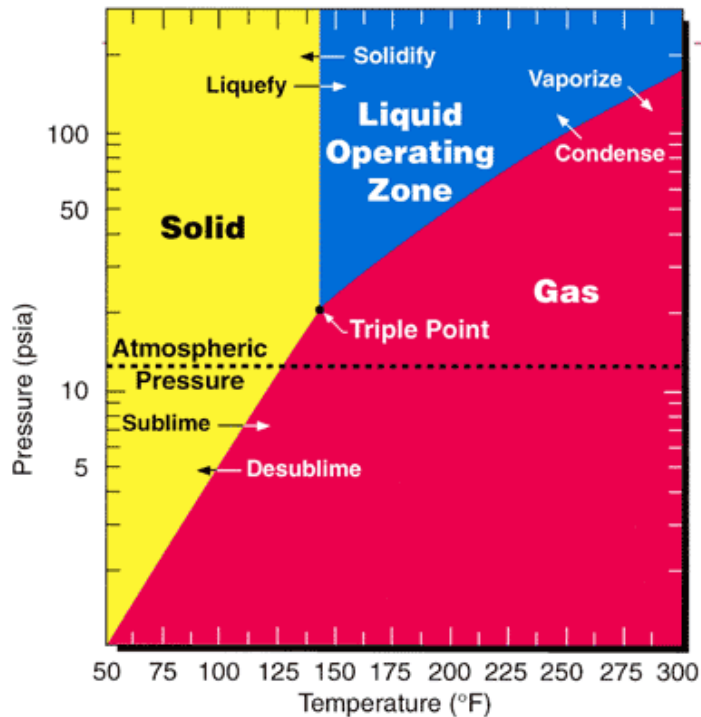

- Gas Phase at moderately low temperatures
- Fluorine has only one stable isotope
- Easy to produce at high purity
- Acts like an ideal gas

Figure 2 – Advantages of Uranium Hexafluoride (UF₆) (USEC)

3. **U²³⁵ Enrichment** – The converted product is delivered to the enrichers in cylinders that are specially constructed for heating, cooling, and storage of uranium hexafluoride in all three phases, solid, liquid, and gas. The enrichers execute a rigid stepwise process that raises the “assay” of U²³⁵ from

the natural 0.711 percent to up to approximately 4.95 percent for the commercial power industry (Low Enriched Uranium or LEU). The process starts with induction of cylinders of feed material, and ends with cylinders of Enriched Uranium Product (EUP) for the power industry at the customer-specified assay, and cylinders of *tails*, which are the by-product of the process. Tails can be thought of as *stripped out* uranium hexafluoride, typically with an assay of about 0.20 to 0.35 percent U²³⁵. The enrichment industry is migrating from the energy-intensive gaseous diffusion process to the centrifuge process, with potential laser isotope separation on the horizon. Commercial enrichers include USEC (United States), URENCO (Europe), Areva (France), and Tenex (Russia). All these enrichers sell to the commercial utilities worldwide. Additionally, several other nations have launched their own enrichment programs, mostly using derivatives of the gas centrifuge. Laser isotope separation is being developed by GE-Silex (GE-Silex uses Australian-developed technology).

4. Conversion to UO₂ and Fabrication of Fuel Assemblies

– the Fuel Fabricators receive the product cylinders from the enrichers, and convert the uranium hexafluoride into uranium dioxide (UO₂). The UF₆ gas is chemically processed to form uranium dioxide (UO₂) powder, which is then pressed into pellets, sintered into ceramic form, loaded into Zircaloy cladding, and constructed into fuel assemblies. The fuel fabricator in the United States is Nuclear Fuel Services in Erwin, Tennessee.

5. Consumption by Power Plants – the power industry and the naval nuclear propulsion program handle the fuel assemblies during fueling and refueling operations, and when the fuel in the reactor is spent, the assemblies are removed and stored in specialized facilities. Techniques for core load, refueling, and spent fuel removal vary according to type of reactor and application.



6. **Spent Fuel Storage** – the storage of spent fuel is currently the subject of much discussion. Spent fuel is typically stored in cooling pools. For commercial power plants, the spent fuel pools are adjacent to the reactor for logistics and radiological controls purposes. Dry cask storage of spent fuel is an option, and eventual underground storage of the casks is contemplated, either at Yucca Mountain (should it be reinstated and licensed) or an alternate location. The legacy and handling of spent fuel is beyond the scope of this paper.

ENRICHMENT PROCESS BASICS

As discussed, the purpose of the enrichment process is to extract a sufficient quantity of fissionable U^{235} such that the resulting fuel elements can sustain critical operations of the power plant. Commercial nuclear power plants typically require enrichment to approximately 4.95% U^{235} , or Low Enriched Uranium (LEU). Enrichment for defense purposes may require Highly Enriched Uranium (HEU). HEU enrichment in the United States was suspended in the last century, when defense needs were fulfilled. However, the ongoing capability to domestically enrich uranium will be important many decades from now, when the Navy will require a source of enriched uranium to satisfy its enduring need for HEU.

The enrichment process follows a similar set of steps, regardless of the isotope separation technology or final level of enrichment (assay). These steps are as follows:

- Liquid sampling of the incoming feed cylinders – it is vitally important to ascertain the starting composition and assay of incoming feed, for accountability of nuclear material, quality of product, and to properly assess the work input that will be

required for isotope separation to the exact customer-specified assay.

- Feeding the enrichment cascade – heating the cylinders and transferring their contents into the enrichment process via sublimation and mixing.
- Enrichment - centrifuge or gaseous diffusion isotope separation in an arrangement of small steps that constitute a *cascade* process.
- Product Withdrawal – the desired assay product is withdrawn from the top of the cascade, cooled, and stored for sampling.
- Sampling and transfer to customer cylinders – the customers require certification of both the assay, and the work amount that goes into the isotope separation for their product. This is accomplished via precision weighing of the product cylinders after the end product has been liquefied and allowed to homogenize in the cylinder.
- Tails storage in tails cylinders – the tails cylinders are cooled and stored for future use as low-assay feed material or nuclear waste.

The key to the enrichment process is the operation of the cascade. In a cascade setup, the uranium hexafluoride undergoes isotopic separation in a series of stages. Each stage produces an enriched product and a depleted product. The enriched product is fed to the next higher stage in the cascade. The depleted product is fed to the next lower stage in the cascade. The desired customer product is withdrawn from the top of the cascade. The tails are withdrawn from the bottom of the cascade. In order to minimize losses from inter-stage mixing, the feed cylinders are fed into a



stage that contains an assay that is approximately the same as the feed assay. Figure 3 illustrates a notional cascade. Figure 3 is valid either for gaseous diffusion or centrifuge operations.

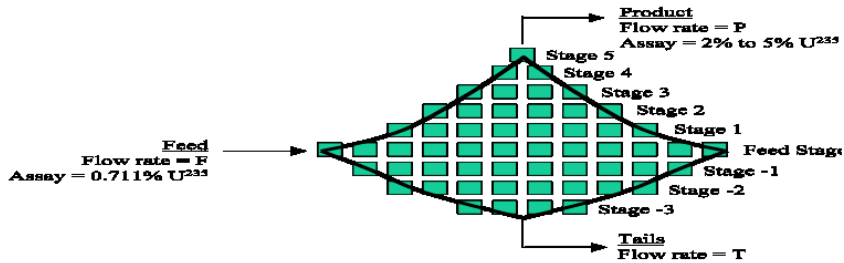

Figure 3 – Typical Cascade Arrangement (USEC)

ENRICHMENT NUCLEAR SAFETY CULTURE AND TECHNOLOGY

Nuclear Safety Culture. All current enrichment plants operate with the majority of plant systems at an elevated temperature and high vacuum. This ensures that the uranium hexafluoride stays in the gaseous state throughout the process. Therefore, the plant systems are carefully monitored for vacuum leaks, for any potential escape of uranium hexafluoride gas, and for temperatures and pressures at all key stages. The enrichment process embraces a nuclear safety culture which encompasses unique practices:

- Critical attention to cleanliness—uranium hexafluoride is an extremely reactive chemical. It combines readily with almost any foreign material, resulting in degradation of the enrichment process.

- Nuclear material control and accountability—because enrichment facilities use appreciable quantities of special nuclear materials, they are accountable for precise inventory control, and periodic audit and high-level security of their operations.
- Chemical safety and vigilance—the escape of uranium hexafluoride gas in an enrichment plant is typically not a threat to public safety or security. However, since UF_6 readily reacts with many other chemical compounds, leak prevention and detection is a must. The most critical concern is combination with atmospheric moisture to form Hydrogen Fluoride gas, which can be lethal if inhaled.
- Nuclear criticality safety—all enrichment plants must adhere to rigid standards that govern the proximity and assay of nuclear materials throughout the process, and must monitor the plant for potential criticality accidents when handling uranium hexafluoride.



Gaseous Diffusion Technology utilizes a compressor/converter assembly to produce isotope separation. The compressor pushes the heavy gas molecules through a diffusion membrane in the converter. The smaller $U^{235}F_6$ molecules diffuse through the membrane, and the larger $U^{238}F_6$ molecules do not. As described above, the enriched stream is fed to the next higher stage of compressor/converters, and the depleted stream goes to the next lower stage of compressor/converters. See *Figure 4* for a typical gaseous diffusion arrangement. An interesting sidelight in gaseous diffusion is that the coolant used for the modern U.S. gaseous diffusion plants was R-114, which is widely used in submarine air conditioning plants.

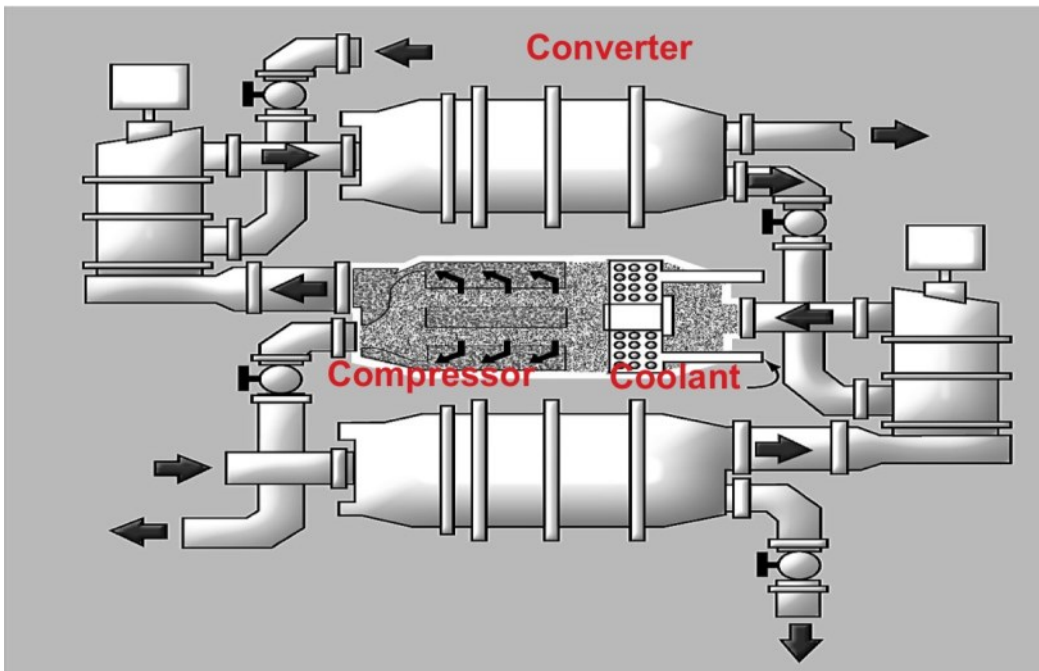

Figure 4 – Gaseous Diffusion Compressor and Converter (USEC)

Gas Centrifuge Technology utilizes centripetal acceleration of the uranium hexafluoride gas molecules to separate the heavier $U^{238}F_6$ molecules from the lighter $U^{235}F_6$ molecules at the wall of the centrifuge rotor. The layering by molecular weight, assisted by flow patterns inside the centrifuge, facilitates isotope separation via a product scoop at the top of the centrifuge machine, and a tails scoop at the bottom of the centrifuge machine. A notional gas centrifuge is illustrated in *Figure 5*.

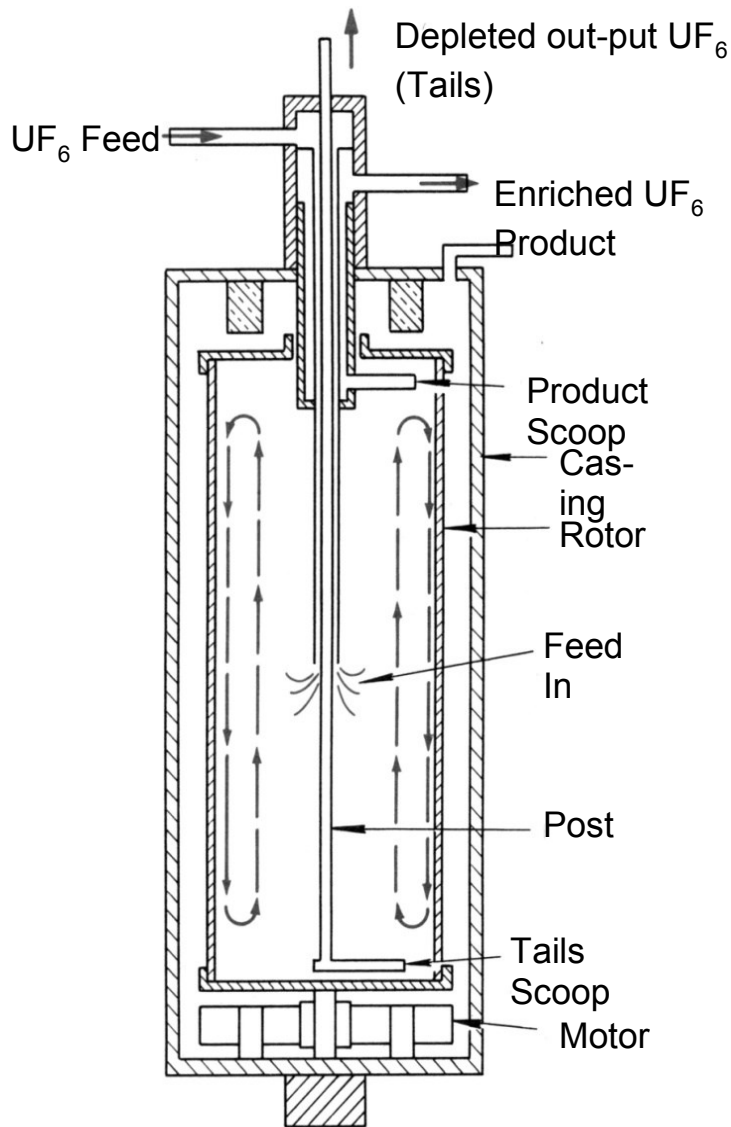

Figure 5 – Gas Centrifuge (JNFL Corp)



SUMMARY

The nuclear fuel cycle is an important underlying process that supports the nuclear power industry. There is an ongoing need for all steps of the fuel cycle to support the approximately 400 commercial power reactors worldwide. The technological sophistication, engineering discipline, careful attention to detail, accountability, and operation in a highly-regulated environment of fuel cycle facilities is consistent with the overall nuclear safety culture of the nuclear power utilities. The United States needs to maintain proper focus on technology development and facilities necessary to meet our country's and world's demands for decades to come.

REFERENCES

1. U.S. Department of Energy (energy.gov)
2. U.S. Nuclear Regulatory Commission (nrc.gov)
3. World Nuclear Association (world-nuclear.org)

AGAINST THE TIDE

by RADM Dave Oliver, USN, Ret.

Editor's Note: This is a chapter from RADM Oliver's new book. Rather than a review, which will follow in the next issue, this chapter is meant to give the reader a sample of the actual text.

Against the Tide is not a biography or a memoir. It instead discusses the interaction of great personalities and how leadership changed our history. The period is the decades after World War II, when the Soviet Union was an economic, military and emotional threat.

Admiral Rickover's nuclear submarines were one of the major tools that Presidents successfully used in this fight.

To make these weapons work, Rickover had to overcome the Navy's strong aversion to change. Specifically, he needed to eliminate the diesel officer submarine community (the same one popularly credited with winning the war just completed in the Pacific), and replace these heroes with young whippersnappers armed with slide rules.

But how was Rickover ever going to infuse his young engineers with the other essential facet of submarining – the bravery it takes to penetrate minefields, ice fields, and reattack under fire? This was the real challenge everyone knew Rickover faced. No one wanted to return to the days of yesteryear. It was not much of a secret that the Submarine Force had spent the first several years of World War II wallowing in ineffectiveness until the commanders without true steel in their hearts had been weeded out.

As will be recalled in *Against the Tide*, for a period in the fifties, the nuclear submarine program was excelling, the Air Force space program could not get a missile off the ground and the Army was tied up with enforcing desegregation in Selma, Alabama. By exception, Rickover and nuclear submarines became the National and International poster child of American success. The Admiral was on the cover of *Time* and *Life* magazines. For nearly three decades Rickover was one of the most easily



recognized military personnel in the world, and goodness knows, he was never loath to give a friendly reporter a quote.

However, time marks even the hardest rock and, after the longest career in the history of the Navy, Rickover was finally forced to retire. Cruelly, he died before the Cold War was won. By that time, his numerous enemies were eager to bury his memory and unwilling to credit his achievements.

Rickover, an essentially private man, never did write an autobiography and never "wasted his time" explaining. As a result, his unique management method has been largely ignored by the business world and generally dismissed (outside the nuclear submarine community). Like the neighborhood butcher in Rickover's Chicago childhood, this book is an effort to put a thumb on the scale to make sure his good management techniques receive their proper recognition.

Planning for Success

More than ambition, more than ability, it is rules that limit contribution; rules are the lowest common denominator of human behavior. They are a substitute for rational thought.¹

Although Rickover was an extraordinary manager and personally controlled submarine construction for nearly four decades, he was not an able Submarine Force representative in the Pentagon meetings that dealt with strategy and warfighting. Unlike most senior managers, Rickover accepted his personal limitations for the good of his cause. He would devise a remarkable solution.

Many maintain that a real leader can do it all—can manage anything. They are positive they can. Rickover knew this was incorrect. A real leader needs not only personality but also domain knowledge. Domains are often different. For example, someone who has never flown an airplane should not make rules for pilots.

While Rickover became uniquely qualified to build the world's best submarines, he had never commanded one. Even more important, he failed the leadership *sight test*. He didn't look like a leader, much less a military one.

Rickover was a slight man, not terribly athletic, and somewhat sensitive about that fact. He also tended to frequently use tools others found offensive. Rickover wasn't terribly interested in polite persuasion. He didn't generally engage unless he believed there was a right and wrong. And why in the world would anyone decide on the wrong solution? So why should he waste time on this conversation? One of Rickover's favorite guidelines, often imparted immediately before he impatiently (and noisily) hung up the phone, was "Do what is right!"

Rickover also didn't have the persona of a typical submarine warrior. He was an introvert with an unusually high-pitched voice.² This was not the picture the public had for the leader of nuclear submarines. They anticipated, as the movies depicted at the time, someone more like John Wayne.³ Hyman G. Rickover was no John Wayne.

The diesel-submarine officers who exited World War II—the men who had used daring to overcome their platform's clear weaknesses—had a swagger about them. The wakes behind these men were virtually awash in the testosterone elements of the day: poker, booze, women, and cigars.⁴ These larger-than-life personalities were acceptable in the Navy because this behavior was popularly linked with legendary submariners. In contrast, Rickover never played poker, did not drink, did not smoke, and avoided any situation that might even imply unfaithfulness to Ruth Masters.

But Rickover well understood the importance of image. He knew his program needed the very best *John Wayne* Americans he could find. Thus, he searched the rolls for men who not only were mentally quick enough to absorb the nuclear-engineering discipline Rickover was developing but could also do what he could not—fill the public image of a submarine officer. He made an unspoken pact with these men. Rickover would teach them engineering and management and stand aside when they took

(nonengineering) chances at sea. Wilkinson was his first discovery.

Cdr. Eugene P. “Dennis” Wilkinson was living in San Diego when Rickover drove in from the Borrego Desert one afternoon. Wilkinson was a submariner’s submariner. He was smart and brave, was acknowledged as a warrior during World War II, and was not particularly interested in ever concealing his abilities under a barrel. It was already a matter of legend that in 1944 Wilkinson had been onboard the submarine USS DARTER when she torpedoed the Japanese cruiser Takao (a warship, not a merchant!). In escaping the counterattack, DARTER had inadvertently grounded herself on a reef in the Leyte Gulf. The muscular, handsome, six-foot-plus Dennis Wilkinson, USS DARTER’s engineer officer and strongest swimmer, dived around and under the ship in shark-infested waters, all alone, before determining that salvaging the boat was hopeless. That night Wilkinson successfully ferried a rescue line to a sister submarine. A Japanese destroyer arrived to find an empty submarine an hour after everyone had escaped via Wilkinson’s lifeline.

Wilkinson portrayed the event for history in the manner diesel submariners were expected to: “During our patrol in the DARTER I had a picture of my wife Janice mounted in my stateroom. As we were about to leave the ship, I ran back down, but I didn’t get my wife’s picture. I got the poker record book—in which I was the one the most ahead.”⁵

This was precisely the type of individual Captain Rickover was seeking. I do not know how Rickover learned that Wilkinson was a deadly poker player (gambling was specifically prohibited by Navy regulations, but Wilkinson’s pasteboard dexterity was legendary),⁶ but it was obvious from his broad chest that Wilkinson was a world-class athlete,⁷ and his Silver Star and campaign ribbons were his bravery credentials. Wilkinson was an exceptional leader, and he looked like one.

Unlike others who lead organizations, Rickover did not resent Wilkinson (although Wilkinson and many other subsequent senior officers who gave their all to Rickover were always surprised—and probably hurt—that he did not ever become their friend).

Comfortable with himself, Rickover did not require the usual emotional approbation as he went about the business of assessing what was necessary for his program's success. This ability to evaluate a situation without worrying about how the assessment would affect his relationships helped make Rickover unusually effective as a manager.

In 1954 Wilkinson became the first Commanding Officer of USS NAUTILUS, the first nuclear-powered submarine. Seven years later, when the first nuclear-powered surface ship was commissioned, Wilkinson was assigned as the initial Commanding Officer of USS LONG BEACH (CGN-9). He would subsequently be placed in charge of the entire Submarine Force, and in retirement, after the disaster at Three Mile Island in 1979, Wilkinson would, as a civilian, become the President and Chief Executive Officer (CEO) of the Institute of Nuclear Power Operations in order to bring the principles of nuclear navy rigor to the civilian nuclear industry.

Since Rickover wore a civilian suit even after he had been promoted to admiral, Wilkinson was the first uniformed admiral I ever met. Wilkinson came on board USS NAUTILUS at 4:00 one morning in 1969 to present me with the Brass Oak Leaves for my collar insignia the day I was approved for promotion to lieutenant commander. He and I subsequently had the normal occasional professional touches until the late eighties. By then Wilkinson had retired to California, and I was the rear admiral in San Diego in charge of the fast-attack submarines on the West Coast. The Cold War was ongoing, and the Pacific Ocean had recently received the first of a completely new class of submarines, the 688 class, to add to our older 594s and 637s.

In honor of his seventieth birthday, I invited Admiral Wilkinson to go to sea for a few days to experience the new undersea capabilities he had been so instrumental in getting funded. Wilkinson accepted. It was to be a revealing visit.

After the admiral had been "piped aboard," he and I walked through the ship. Dozens of sailors wished to meet the legend. He graciously spoke to each one and listened as they proudly bragged about their new equipment. During the ninety minutes the ship



was clearing San Diego Harbor and preparing to dive, we walked the football-field-plus-long ship, passing literally thousands of valves and cables as we did.

Unlike previous classes of submarines, the 688-class, for ease of inspection and cleaning, did not have any covering over the areas in which the ship's runs of pipes and valves and cables were laid. As one consequence, the eight-to-eleven-digit aluminum tags identifying each of the hundreds of electrical cables were visible from the narrow passageways by which sailors moved fore and aft.

Admiral Wilkinson's initial social duties accomplished, the two of us retreated to the wardroom while the ship's crew went about the serious business of getting the ship underwater and properly compensated (submerged and balanced fore and aft, accomplished by taking in or pumping out ballast water until the weight of the ship and the water displaced were the same). The wardroom was relatively small, intended to seat eight to ten officers snugly for meals, but for the moment there were only the two of us.

Admiral Wilkinson settled back on one of the Naugahyde-covered benches, warming his hands with a mug of coffee. He was still a lean man, about six feet two or three, four or five inches taller than the comfortable height in a submarine. As a result, he bent slightly forward at the shoulders. His eyes compensated for this odd posture. They were always focused on his listener.

His first words to me were a challenge: "Would you like to know the numbers on each of the cables we passed in the order we passed them or in reverse?"

For a long moment I thought he was kidding. He was not. He gave me a couple of eleven-digit numbers. I wrote them down and then went out in the passageway and checked. He was absolutely accurate. I knew he was smart; I had not realized he was also a number savant. I decided not to play poker with him. Instead, I pulled out the cribbage board, dealt us each six cards, and asked him how he had begun in nuclear power. The story he told revealed a lot about Rickover's deviously effective determination.

When he first met Rickover, it was 1947. Wilkinson was a lieutenant commander serving as the executive officer on the first

missile-firing submarine, USS CUSK (SSG-348).⁸ World War II was over, and Wilkinson and his wife, Janice, were living in San Diego, where they had both grown up.

Whenever he had free time, Wilkinson would drive up to the University of California–Los Angeles (it was possible to get from San Diego to LA and back in much less than a fortnight in those days) to further his personal study in the mysterious new field of nuclear physics (he had completed everything for his PhD except his dissertation). As he spoke to Rickover at that initial meeting, it became obvious that the captain had screened every naval officer's record before he had driven across country to interview Lieutenant Commander Wilkinson.

Wilkinson told me he had immediately agreed to be a part of the nuclear-power program, and a short time later he and Janice joined Rickover's small team in Oak Ridge, Tennessee, where Wilkinson began work on the design of a core for a submarine reactor.

Rickover was in the habit of taking his own people to meet with experts in the burgeoning nuclear field, and some months after Wilkinson had reported to Oak Ridge, the two of them headed north. Rickover was scheduled to meet Enrico Fermi at the University of Chicago. At that time Fermi was the best-known nuclear physicist in America. He had won the Nobel Prize for Physics in 1938 and on 2 December 1942 had established the first sustainable nuclear chain reaction in the world in the uranium pile he had built on the rackets court under Alonzo Stagg Field, home of the Chicago Maroons football team.

When Rickover and Wilkinson arrived, Fermi was busy with his slide rule, calculating the flux and buckling numbers basic to the new reactor he proposed to build. Rickover and the young Wilkinson sat across from him at his desk. As Rickover and Fermi talked, Wilkinson studied a couple of pages of calculations he could see scattered across the blotter. They were upside down but legible.

After fifteen minutes Wilkinson rose and wordlessly went to one of the chalkboards that surrounded the room. There he began writing from the point he believed Fermi had left safe theoretical

ground, through the error he posited in Fermi's calculations to calculations Wilkinson thought led to the correct path. Fermi, who had swiveled in his chair to watch the chalk-board work, stopped speaking to Rickover. He instead pulled his papers over to reinspect his work as he followed Wilkinson's white numbers with increasing interest.

After ten minutes he slowly nodded his agreement. "Maybe."

An hour later Fermi, slide rule in hand, was standing at the board with Wilkinson, saying, "Right," and returning to his desk occasionally to erase some numbers on his papers and scribble in new ones. He was obviously impatient for the Navy men to leave so he could rethink his buckling problem in private. Wilkinson recalled that Rickover was equally ready to conclude the discussion.

As soon as they left Fermi's office, Rickover made a telephone call from a pay phone and then began searching for a Salvation Army second-hand store. When they found one, he purchased a light brown suit, deliberately two sizes too large, for his companion. The following morning it was reveille at dawn for both of them so that they could make the remaining ten-hour drive to downtown Washington. Rickover was impatient. The previous day's telephone call had been to the chairman of the Joint Committee on Atomic Energy, Senator Brien McMahon from Connecticut.

After World War II, Congress had established the Atomic Energy Commission (which would subsequently become the Department of Energy in 1970) as the successor to the Manhattan Project. The Atomic Energy Commission (commonly abbreviated AEC) was fully responsible for the development of atomic energy for the United States. Captain Rickover had already been designated to lead the Navy portion of the AEC nuclear program.

During the Fermi discussion, Rickover had conceived an idea that would prove critically important to the history of nuclear power in the Navy.

Since the AEC was responsible for the development of atomic energy, the commission's budget funded designing and developing the reactors for the Navy's submarines and surface ships. The

AEC budget also bought the reactor cores for these ships. The Navy and Department of Defense funded everything else involved in the construction and maintenance of submarines and surface ships.

This arrangement—having two different government agencies or departments in control of two essential pieces of the same program—may seem feasible in theory but is terrible in practice. As the Good Book must somewhere say, having two government agencies in charge of one project was, and ever shall be, an invitation to pass “Go” and proceed directly to hell.

Unfortunately, it was not an easy problem to fix. There was absolutely no chance that either organization would yield any power. Power equals control of dollars, and no one in Washington gives up control of money. Unless one person was in charge (and making the necessary trade-offs and accommodations among capabilities, schedule, and time), there was practically no chance the two parts of the ship would be delivered on the same schedule. This equates to planning for automatic cost overruns.

While Rickover and Wilkinson were speeding across Ohio and Pennsylvania, the AEC was mulling over whom it would appoint to head its naval section. On the one hand, it could be a friend of Rickover’s or, more likely, a retired naval officer (who, given the politics of the Navy, would not be Rickover’s friend). Given the current prominence of Enrico Fermi, it could well be one of the Nobel Prize winner’s disciples. If it were the latter, the mantle would probably fall to Dr. Walter H. Zinn, who had recently been assigned the directorship at the Argonne National Laboratory in Illinois, the U.S. center for reactor development. Dr. Zinn was not overly fond of Rickover and definitely not in favor of aggressively pursuing a nuclear submarine until his laboratory had several more years to evaluate the options.

Whoever was assigned, it would still be an invitation to the devil to dance, and Rickover knew that even if he could successfully build and launch USS NAUTILUS, no one, not even the President of the United States, had the power to make two overlapping government agencies work together. It is difficult to manage one agency and impossible to coordinate two.⁹ The costs

and frustration of a nuclear armada would inevitably sky-rocket out of control—and Rickover’s vision of a nuclear-submarine fleet would be sunk before it floated.

Vice Admiral Wilkinson told me that they parked on Capitol Hill and walked to McMahon’s Senate office. Rickover frequently did not share either strategy or tactics with his subordinates, and this time the only direction Rickover gave Lieutenant Commander Wilkinson was to sit in his oversized brown suit—which must have literally hung on his tall, gaunt frame—on the couch as far away as possible from the senator’s desk. Of course, no office in Congress, even for an important committee chairman, is very large, and the chairman and Captain Rickover’s conversation was easily overheard.

“Rick,” said the senator, shaking his head in disagreement, “I and the members are more than a little inclined toward a civilian appointee. I think that is where we must go.”

“Mr. Chairman, I truly respect what you and your committee are doing for our country, but I know that would be a mistake.” Rickover paused to let foreboding creep into his voice, and the poker player bones in Wilkinson thoroughly approved of the performance. “And I saw something yesterday that convinced me I should bring this directly to your notice.”

Rickover had lowered his voice with the last few words, and Wilkinson watched the senator lean attentively forward. “Mr. Chairman, I have been traveling around the country, and I have assembled the very best team of Americans to work on nuclear power. There is nothing like them in the civilian world.”

Rickover inched his heavy chair closer to the senator’s desk. “You know I would never say something bad about someone, but that fellow over there [gesturing dismissively with his thumb back at Wilkinson] and I were talking to Enrico yesterday in Chicago, and something happened to make me come straight to see you.”

Wilkinson laughed at the memory of that day years ago, took a sip of his coffee, and spread his large hands out on the wardroom table. He continued his story:

“The senator looked over at me, sized up that ugly oversized brown suit plus the fact that I was three or four weeks overdue for

a haircut, and his lips came together tighter than a man eating green persimmons.

“Rickover had been watching the senator’s face just as I had, and when he saw the expression he had been expecting, the Old Man closed for the kill. First, he lowered his voice so that I could just barely hear him, and I was only six feet away.”

“Senator,” said the captain, “I have to tell you, that man back there is the dumbest member of my Navy team, and he is smarter than Enrico Fermi.” Wilkinson chuckled, “I could see the disbelief spread on the chair-man’s face.”

As Rickover leaned across the desk and used his elbow to inch the senator’s telephone closer to his hand, he consciously pitched his normally high voice lower. “This is important, Senator. Call Enrico and ask him. That officer back there’s name is Wilkinson. Ask Fermi if Wilkinson is smarter than him. I am telling you he is.”

The chairman looked at Rickover for a second, never glancing at the young Wilkinson, and then resolutely dialed Fermi. Rickover and Wilkinson could only hear the senator’s side of the conversation.

“Fermi, Rickover is here in my office, and he says that some young officer named Wilkinson on his team is even smarter than you. I can’t believe that.” There was a long pause while the congressman listened to the Nobel Prize winner renowned for his personal modesty. Finally the chairman cradled the telephone, cast one more doubting look at the tall man in the brown suit on the sofa, and spoke quietly to Rickover. “Enrico says you are correct: Wilkinson is smarter than he is.”

Even when he was being played, the senator was no one’s fool. His voice contained his suspicion. “What do you propose?”

Rickover pulled from his inside coat pocket the two-page draft joint committee legislation he had worked on while Wilkinson had driven that morning. “To maximize the safety of nuclear power in the United States, I think your committee should establish my Navy team in charge of the aspects of the Atomic Energy Commission that affect the Navy.”

The chairman reached for the papers, slightly shaking his head,

his lips again pursed. "I don't see how we could have a Navy team in the Atomic Energy Commission. . . . Perhaps we should just appoint you as the head of that particular portion of the atomic energy team."

Rickover, frowning, let the papers slide from his grasp into the chairman's hand. From his long hours at the poker table, Wilkinson realized his boss's frown was as insincere as the secondhand brown suit he was wearing. "I thought you might have that concern, Mr. Chairman, so I made your suggestion the preferred option."

As our new 688-class submarine finally broke free from surface tension, nosed down, and slowed its rolling, the steward came in to fill our coffee mugs. In another few minutes, many of the ship's officers would arrive, eager to meet Vice Admiral Wilkinson, the first nuclear commanding officer in the U.S. Navy. He would spend each waking moment over the next few days talking to them about his role in building a nuclear navy.

Before the ship's commanding officer, still wearing his brown sweater from the bridge, entered the wardroom, Wilkinson quietly finished his story: "Two weeks later Congress established Rickover as the director of naval nuclear energy in the Atomic Energy Commission, where he has remained until this day.

"No one ever figured out how he did it." Wilkinson grinned, and we both tipped our coffee cups in silent homage to Rickover's foresight and willingness to take risks to achieve his vision.

In this chapter I maintain that Rickover could anticipate the future. I also make the point that Rickover would do whatever was necessary to succeed, including picking individuals very different from him personally but who could better represent nuclear submarines (and his principles) in the rough push and shove of the operational side of the Navy.

Have you ever met anyone who could look far enough ahead to plan for obstacles not yet visible? Is this unusual and extraordinary ability to see the future perhaps one of the discriminating characteristics some unconsciously consider when they seek to differentiate between management and leadership?

In the oral histories of the senior nuclear submariners of the

Rickover era, many imply that they never felt close to Admiral Rickover. Recognizing that familiarity is a tool commonly used to bind managers together, why did Rickover not use this device? Is familiarity a useful tool for managers? Was it possible for Rickover, given his own personality? Can a manager be close to his subordinates and still maintain his objectivity?

ENDNOTES

1. Rickover, speech delivered to Naval Postgraduate School (1954).
2. It is extraordinary that Rickover was able to overcome his introversion as well as he did. To judge the extent of this characteristic, see Blair, *Atomic Submarine*, about Rickover's experiences as a submarine executive officer: "As time passed, however, conditions on the S-48 went from bad to worse for Rick. He and the commanding officer did not see eye to eye. Moreover, some of the men did not believe Rick was the sort of happy-go-lucky submarine officer they wanted to follow. He stubbornly refused to go ashore and associate with the other officers when the S-48 was on a cruise. He preferred to take lone exploration trips to the interiors of the foreign countries they visited, or spend his spare time studying more Naval War College correspondence courses" (p. 53). In a personal conversation in early 2012, Ted Rockwell, Rickover's first senior engineer, told me that Blair wrote his book from an office in Naval Reactors' spaces with editorial assistance from Ruth Masters Rickover. Rockwell was spearheading an effort to get Rickover promoted from captain to admiral, and he planned to use Blair's book and articles for that purpose. One would thus suspect the book presented the admiral in as favorable a view as possible.
3. John Wayne was the submarine commanding officer in the very popular World War II movie *Operation Pacific* (1951).
4. It is almost impossible to exaggerate what was acceptable at the time. I well recall a particular commanding officer who routinely drank excessively and also invited different women to share his spousal bed. He was an effective warrior, and for many years his excesses were largely ignored. Finally, he reached the professional breaking point when he managed to steer his submerged submarine into both Pacific shores—the coral of Japan and the rock of San Diego—during the same voyage. He was relieved.
5. Wilkinson, "Abandoning the Darter," 185.
6. From my personal experience, I know that well into his nineties, Admiral Wilkinson was still making money in the cutthroat California poker parlors.
7. Wilkinson played championship tennis throughout his Navy career. See his *Reminiscences*.
8. Wilkinson, *Reminiscences*, 105–11. They were firing captured German V-1 rockets, or Loons, a predecessor to the Regulus program, which in turn would lead to the Polaris, Poseidon, and Trident programs.



9. The most recent demonstration of this was the difficulty in coordinating Defense, State, and Treasury during the 2003–13 Iraq War.

***Advance praise for Against the Tide* ~**

“I enjoyed this book enormously. This is the perfect match of author and subject—an appreciation of a famous and controversial admiral by an intelligent and inquisitive veteran of the Navy’s submarine force. Admiral Oliver analyzes how Admiral Rickover, a very late bloomer, overcame massive internal resistance to build a revolutionary new class of ship—the nuclear-powered submarine. At times it reads like a thriller, at other times like a good study of how to run a business. But it is always informed and informative. It also is one of the best books ever written about submarine command.”

—**THOMAS E. RICKS**, author of *Fiasco* and *The Generals*

“Oliver, like his mentor Rickover, is an unconventional and unorthodox man who believes that strong and ethical character guided by a moral compass underlies personal responsibility. He sees these traits as the foundation for good management and good leadership, a view that could serve contemporary leaders in government and industry well.”

—**THOMAS ENDERS**, chief executive officer, Airbus Group

“*Against the Tide* captures the extraordinary technical advances Admiral Rickover drove into American industry and the cultural changes he insisted on within the nuclear Navy. . . . Dave Oliver describes the uniquely successful management style Rickover established that resulted in the nuclear Navy’s major contributions to our winning the Cold War and to the continued untouchable safety record of today’s nuclear Navy.”

—**ADM. FRANK L. “SKIP” BOWMAN, USN, RET.**

“In America today we face two significant challenges: strengthening our economy and protecting our nation. *Against the Tide* provides invaluable insights into both of these issues and

illustrates the symbiotic relationship between them. Adm. Hyman Rickover was a unique American, and his legacy of excellence, vision, and patriotism still offers lessons to us today.”

—**BOB RILEY**, former United States Congressman and 52nd Governor of Alabama

“Admiral Oliver weaves a series of fascinating, often humorous stories around the leadership/management principles of Hyman Rickover, providing unique insights into the challenges, intrigue, and successes of the nuclear Navy. Not just another book on leadership, this book spells out an approach to balancing process discipline and innovation in the development of large-scale, complex systems operated in the most unforgiving of environments.”

—**JIM ALBAUGH**, retired president and CEO, Boeing Commercial Airplanes; president, the American Institute of Aeronautics and Astronautics



THE SINKING OF THE GLOMAR EXPLORER IN 1974

by Captain Jack O'Connell, USN, Ret.

Captain O'Connell is a frequent contributor to The Submarine Review.

This is a story about *a sinking that didn't take place*, but very well might have if circumstances had changed.

In early June 1974 I had recently reported to ComSubPac staff and relieved the Assistant Chief of Staff for Operations, Plans and Intelligence (N3), having come from a posting as Chief Staff Officer at Submarine Group Seven. I was familiar with submarine special operations conducted by both commands, having taken part in eight such operations from 1956 through 1967, including two while in command of USS SPINAX (SS 489) during 1966 and 1967. However, as the new N3 I found myself admitted into a new security compartment, dealing with covert deep water recovery operations.

In March 1968 a Soviet Golf-class ballistic missile submarine was approaching its assigned patrol station roughly 1,000 n.miles northwest of Pearl Harbor. K-129 carried three liquid-propellant R-21 ballistic missiles (NATO designation SS-N-5 Serb), with a range of about 755 n.miles. K-129 was assigned to the *Hawaii Station*, not quite in range of the primary targets of Pearl Harbor naval base, Hickam Air Force base, and CINCPAC headquarters at Camp H.M. Smith, but close enough to readily move into range if international tensions called for a higher degree of readiness. Her missiles could be launched submerged as deep as 165 feet and while traveling as fast as 4 knots. The circular error probable of the R-21 is listed as 2.8 Km (1.7 miles), but a 1 megaton warhead would make up for some inaccuracy.

About midnight on 11 March 1968 the K-129 suffered a fatal accident. The after two R-21 ballistic missiles ignited their liquid-fuel motors in sequence in their launch tubes in the after end of the sail with the tube muzzle doors shut, while the submarine was at periscope depth. The rockets exhaust burned through the bottom of the launch tubes and into the submarine pressure hull and killed all hands. The submarine sank.

The acoustic events involved were detected by a U.S. Navy cable ship, USNS ALBERT J. MEYER (T-ARC 6), then conducting acoustic research in the eastern Pacific Ocean, and by a series of hydrophones operated by the Air Force Technical Applications Center. AFTAC's data led to *pinpointing* the events at 40 degrees 6 minutes North, longitude 179 degrees 57 minutes East, plus or minus two miles. Soviet communications activity and observations of searches being conducted in the vicinity of Petropavlovsk led the U.S. Navy to the conclusion that a Soviet submarine had gone missing.¹

These events led to detailed discussions in Washington between the Navy and the CIA. The lost submarine was identified as a Golf-class SSB, with R-21 ballistic missiles and a pair of type 53-58 nuclear warhead torpedoes. In addition, the lost submarine undoubtedly had highly classified cryptographic material aboard.

Following her career as a guided missile submarine USS HALIBUT (SSN 587) had been converted into a covert deep-search platform, employing *fish* (towed sensor vehicles) from her former Regulus missile hangar to search the ocean bottom for intelligence targets. After extensive search operations in August 1968 Halibut was successful, and brought back pictures of K-129 lying on the bottom in two pieces in 16,800 feet of water but otherwise relatively intact. The forward, larger section included the first missile tube, with presumably an intact R-21 missile in it.²

The next step was to commit a large amount of money to fund a deep water recovery operation. Unlike HALIBUT's operations that were concealed beneath the ocean surface, a recovery vessel would have to operate in plain sight. The United States was aware that the Soviet Union did not know the location of the sunken K-129 and had no inkling of U.S. knowledge, but undoubtedly would

be sensitive to recovery operations in the general vicinity. Therefore the true purpose was hidden in a cover story about mining the deep ocean for manganese nodules using a special ship funded by Howard Hughes, the famous eccentric millionaire. On 4 July 1974 the Glomar Explorer began operations in the vicinity of the K-129.

Admiral Mickey Wisner was Commander in Chief, U.S. Pacific Fleet. Very few people in his fleet knew anything about the true purpose of Glomar Explorer. In fact ComSubPac's own Chief of Staff, Captain Logan Malone, was not yet read into the program. Wisner specifically forbade any contingency planning for what might happen in the event that the Soviets became aware of Glomar Explorer's mission.

Rear Admiral Frank McMullen was Commander Submarine Force, U.S. Pacific Fleet. He called me up to his office and gave me very specific instructions. We (ComSubPac) would have a 594-class SSN on alert and ready to sail on a moment's notice. She would be *loaded for bear*, that is a heavy load of anti-ship torpedoes instead of the usual mix of anti-submarine and anti-ship torpedoes that were called for in the applicable ComSubPac standing operations order. Nothing was to be committed to writing. In the event that the Soviets became aware of the Glomar Explorer's true mission, and seized her, ComSubPac would have a fast SSN available to speed to the scene. Whether the SSN's potential targets would be Soviet ships or the Glomar Explorer wasn't discussed. Sinking a Soviet ship might be construed as an act of war, but sinking an American registry ship would be a different kettle of fish. In any event, ComSubPac would be ready to respond to national tasking in an emergency.

I called Commander Submarine Squadron 1, Captain Roy Wight, a close friend, up to my office. I told him that ComSubPac needed a 594-class SSN on alert all summer long, with a heavy load of anti-shiping torpedoes for an unspecified mission under ComSubPac operational control. I told him that it was a top secret, compartmented matter, and that he knew as much as he would probably ever know about the subject. Looking at the 594 SSN schedules, it was apparent that at least two 594s would have to be

designated to assure that one was ready to sail while the other one might be in an upkeep status. It helped that I held an additional *hat* as Commander Submarine Group, Hawaiian Area, and could direct local submarine movements. The two 594s were designated, and their COs told as little as possible. We then all sat back and held our breaths.

The Glomar Explorer was only partially successful in retrieving part of the forward K-129 hull. An accident took place that fractured a lifting claw and while the forward section was on its way up to Glomar Explorer's *moon pool*, the after part of the hull fell back onto the ocean floor and shattered into many pieces. The unfired R-21 rocket was lost along with any cryptographic material. About 7 August 1974 Glomar Explorer left the wreck site, never to return. Although Soviet surveillance vessels had operated close aboard Glomar Explorer during her search and lift operations, they never had a clue about what she was actually doing, until 7 February, 1975 when a Los Angeles Times front-page story exposed her operations to the world.

I was very happy that we had no occasion to use anti-ship torpedoes against Glomar Explorer. A fellow submariner, good friend and fellow staff mate, Captain Fred Terrell, was embarked in her. He was the officer who read the Soviet Navy burial service over the remains recovered from the forward section of K-129.

ENDNOTES

1. Polmar, Norman and White, Michael, Project Azorian, the CIA and the Raising of the K-129, Naval Institute Press, Annapolis, Maryland, 2010.
2. The commanding officer, Commander Edward Moore, was awarded the Distinguished Service Medal, and the ship – the Presidential Unit Citation.



AMI HOT NEWS FROM AROUND THE WORLD

Reprinted with permission from AMI HOT NEWS; an Internet publication of AMI International, PO Box 40, Bremerton, Washington 98337.

From the August 2014 Issue

INDIA

Fast Tracking SSNs and Diesel Boats?

As of mid-August 2014, AMI continues to receive information that the Indian Navy (IN) is interested in combining and fast tracking its two future submarine programs, the Future Nuclear Powered Attack Submarine (SSN) and Project 75I, the acquisition of up to six diesel electric submarines with a vertical launch capability (VL) for BrahMos.

The Ministry of Finance (MoF) has recommended to the Ministry of Defence (MoD) to combine the two projects into a single request in order to get the nod from the Cabinet Committee on Security (CCS) on both projects at the same time (no specific timeline mentioned). The two projects have been in limbo between the MoF and MoD for the better part of ten years, requiring pre-approval by the CCS every two to three years. From the outside, it appears that the new Indian Administration (Prime Minister Modi) is serious about national security and has made it a priority to start moving ahead with long delayed national security programs.

ASIA-REGIONAL UPDATE

THAILAND - Submarine Command: On 07 July 2014, the Royal Thai Navy (RTN) established a submarine squadron at the Sattahip Naval Base. The establishment of a submarine squadron indicates that the RTN still envisions owning a Submarine Force. However, all attempts to acquire a submarine over the past decade have resulted in no new or used submarines.

The RTN officially has an official submarine requirement in its latest ten year plan that runs through 2018 although funding and political turmoil continue to stall any submarine procurement plans.

SOUTH KOREA – Son Won-II (Type 214) Class Submarine, On 15 July 2014, the fifth Republic of Korea Navy's (ROKN) Son Won-II class submarine, ROKS YUN BONG GIL HAM (S 077), was launched at Daewoo Shipbuilding and Marine Engineering (DSME).

AUSTRALIA – Collins Class Submarine Maintenance Contract Extension: On 05 August 2014, ASC Pty Ltd announced that it has been re-contracted to provide maintenance on the RAN's fleet of six Collins class submarines. Under the In Service Support Contract (ISSC), the ASC contract covers all mid-cycle and intermediate maintenance work for the entire class.

All work will be accomplished at ASC's Osborne facility in Adelaide, South Australia and Henderson in Western Australia.

RUSSIA: Delta IV Class Nuclear Powered Ballistic Missile Submarine (SSBN) YEKATERINBURG (807): On 27 July 2014, the Russian Navy (RVF) refloated the Delta IV class SSBN YEKATERINBURG (807). The SSBN will complete repairs on the submarine by early 2015. YEKATERINBURG was damaged in a December 2011 fire. The repairs were conducted at Zvezdochka Shipyard.

USED SHIP TRANSFERS/ RECEIPTS/DECOMMISSIONINGS

UNITED STATES – NAVY DECOMMISSIONINGS: Los Angeles class Submarine: USS LA JOLLA (SSN-701) and USS NORFOLK (SSN-714).

From the September 2014 Issue

MODERNIZATION AND SHIP TRANSFER

AUSTRALIA – Collins Class Submarine: On 12 August 2014, Thomas Global Systems signed a contract with Saab Australia Pty Ltd to provide technical support and electronic manufacturing of key components for the Integrated Ship Control Management and Monitoring System (ISCMMS) upgrade of the Royal Australian Navy's (RAN) Collins class submarines.



Saab was awarded the contract for the ISCMMS upgrade project by ASC Pty Ltd in November 2013. Thomas will provide the driving console components and other critical electronic control modules for the six submarines from 2014 through 2015. The ISCMMS upgrade will be completed on all six submarines by late 2016.

ECUADOR - Shyri (Type 209/1300) Class Diesel-Powered Submarine (SSK): In January 2008 the Ecuadorian Navy (Armada de Guerra, ADG) Contracted with ASMAR shipyard in Chile for the mid-life refit of its two Type 209/1300 submarines, SHYRI (S101) and HUANCAVILCA (S102). SHYRI entered ASMAR in 2009; however work was delayed due to the Chilean earthquake and tsunami in February 2010. All work was eventually completed for SHYRI in 2012 and the submarine was returned to service. HUANCAVILCA entered ASMAR September 2011 and all refit work was completed by August 2014. The work package for each submarine included:

- Hull, Mechanical and Engineering (HM&E) work.
- Replacement of batteries and machinery control system.
- Replacement of inertial navigation system.
- Replacement of both periscopes.
- Installation of the DCNS Submarine Tactical Integrated Combat System (SUBTICS) with assistance from Chile's SISDEF.
- Installation of Thales S-Cube sonar suite with MBDA SM-39 Exocet submarine-launched, anti-ship missile (ASM) and the WASS Black Shark heavyweight torpedo.

DCNS of France provided technical assistance for this refit project. Total cost for the mid-life upgrade for both submarines was around US\$125M. This project will extend the service life of the Shyri class to around 2025.

SOUTH AFRICA – Heroine Class Diesel-Powered Submarine (SSK): In August 2014, the South African Navy (SAN) again delayed the modernization package for the Heroine class

submarine (SSK) SAS CHARLOTTE MAXEKE (S102) for the near term due to funding shortfalls. SAS CHARLOTTE MAXEKE (S102) and the SAS QUEEN MODJADJI I (S103) have been waiting for their respective refits since 2007 when the first unit of the class, SAS MANTHATISI (S101), completed its overhaul at Simon's Town Dockyard.

All three submarines were scheduled to undergo major refits in accordance with the SAN Maintenance and Upkeep Plan for the Medium to Long Term Expenditure Framework. However, funding shortfalls since 2007 have prevented hulls two and three from undergoing the modernization efforts.

Similar to hull one, SAS MANTHATISI (S101), when funding does become available, the anticipated work package will include:

- Replacement of batteries.
- Installation of hydrogen release system.
- Repair main electrical system.
- Replace main diesel engine.
- Repair of damaged aft steering planes.

AMI estimates that the SAN may have to delay the modernization effort for the two remaining submarines for at least three more years (2017).

RUSSIA – Kilo (Project 877) Class Conventionally Powered Attack Submarine (SSK) VLADIKAVKAZ (B-459): On 27 August 2014, the Russian Navy (RVF) will refloat the Kilo (Project 877) class submarine, VLADIKAVKAZ (B-459), on 19 September 2014. The submarine is being overhauled at Zvezdochka Shipyard in Severodvinsk. It will be recommissioned in late 2015 and returned to the Northern Fleet.

RUSSIA – Kirov Class Nuclear Powered Cruiser (CGN) RFS ADMIRAL NAKHIMOV: In late August 2014, AMI received information that the overhaul of the Kirov class CGN RFS ADMIRAL NAKHIMOV has been delayed until October 2014. Planned to start in early summer at Sevmash Shipyard (Severodvinsk), the first of three CGNs will be overhauled and then re-commissioned by 2018.



The RFS ADMIRAL NAKHIMOV will be followed by RFS ADMIRAL LAZAREV and RFS ADMIRAL USHAKOV. All three were removed from service in the 1990. The cruisers are to undergo a complete refit, specifically:

- Hull maintenance and repair.
- Upgrade of main propulsion system.
- Upgrade auxiliary systems.
- Upgrade combat management system.
- Upgrade all combat systems and communications systems.

The estimated cost of modernizing each cruiser is US\$580M. If the reactivation of RFS ADMIRAL USHAKOV and RFS ADMIRAL LAZAREV do not move forward following the RFS ADMIRAL NAKHIMOV, both units are expected to be fully operational after 2020 and will remain in service until the 2035 timeframe.

From the October 2014 Issue

NETHERLANDS/NORWAY/SWEDEN

Joint Submarine Program – In mid-September 2014, AMI received information that the Royal Netherlands Navy (RNIN) intends to join Norway and Sweden in a new construction submarine program. The RNIN's first submarine is scheduled for delivery by 2023.

Prior to this announcement, all three countries were planning for future submarine programs to replace their respective existing forces. The Dutch were in the early planning stages to replace the four Walrus class beginning in 2023. The Norwegians were working on Project 6346 (Ny Ubat) (new Uboat) to replace the six units of the Ula class. A decision was expected by the end of 2014 as whether to build a new class or further modernize the Ula class. If a new construction solution was chosen, the program was expected to begin in 2017 with the first unit entering service after 2021. The Swedish were also in the process of developing the new A26 design to replace its two Sodermanland and two Gotland

class. The program was expected to start in 2016 with first deliveries around 2021.

All told, the three navies have a requirement for a total of 14 submarines and all with a similar procurement timelines. It makes sense that all three would join forces in order to reduce costs (design savings and economies of scale for 14 hulls) and reduce risk for all three partners. This is similar to the new defunct Viking program that was cancelled in 2007 in which Sweden, Norway and Denmark were members. Denmark has since eliminated a submarine capability in their navy.

With the individual submarine programs expected to start over the next several years for all three partners, a design decision will have to be made in the near term. AMI anticipates that all three programs will utilize a similar hull, the Swedish A26, with national variances for each country. The question is, who will maintain the design intellectual property (IP) rights for use in the export market? AMI expects this program will serve as momentum for the new Saab/Kockums conventional submarine export campaign. If that is the case, AMI expects the Dutch and Norwegian Governments to seek some cost benefits/reductions for joining into this tri-national program.

It appears from the outset that Sweden may be the primary builder for all three countries with modules also being built in the Netherlands and Norway. Sweden's SAAB/Kockums has the most recent experience in the submarine construction and its main yard remains open. The last Dutch submarine was completed at Rotterdamse Droogdok Maatschappij (RDM) in 1994 and the yard is no longer open. Norway's current submarines were assembled in Germany although some of the modules were built in Norway. This would speed up the timelines for deliveries to all three sea services. To restart the submarine industry in the Netherlands or Norway would be cost prohibitive. The building of modules would be much easier and well within the capability of both countries.

After the cancellation of the Viking project in 2007, there is again movement in Northern Europe to consolidate the submarine programs of various nations in order to reduce cost and risk during a very restrictive budget environment. In addition, several crises in

Eastern Europe and the Middle East are beginning to up the priorities and fast forward the timelines of new construction programs in many parts of the world.

DID YOU KNOW?

FRANCE: On 29 September 2014, the French Navy (FN) ordered its fourth Suffren (Barracuda) class nuclear powered attack submarine (SSN), Duquesne, from DCSN. The hull will be built in Cherbourg and will be commissioned around 2023.

8 APRIL 1964
TO A GRADUATING CLASS
A SPEECH BY R.E. THOMAS, CAPTAIN USN, RET.

June 2001 - Foreword by Captain Thomas:

I was the Weapons Officer and sometimes Acting Executive Officer of Submarine Base New London. Captain Reuben Woodall was the Officer in Charge of the Submarine School. He asked me to give the commencement address for the graduation of the 298th Basic Enlisted Submarine Class which graduated on 8 April 1964. R.E.T.

Captain Woodall, Chaplain Tubbs, Members of the graduating class, families, and friends. Our purpose in gathering here today is to render honor to the 298th class to graduate from the Basic Enlisted Submarine School and to welcome them into the Submarine Force.

The past performance of submariners and their boats is recorded in the glorious history of our Navy.

Performances such as those of the submariners of World War II, when they sank over 55 percent of all Japanese ships sunk, earned 7 Medals of Honor, countless Navy Crosses, Silver Stars, and other honored decorations.

Deeds such as those accomplished in 1949 by the men of the diesel powered PICKEREL, when they transited 5200 miles from Hong Kong to Pearl Harbor without surfacing.

Accomplishments of the men of NAUTILUS in reaching the North Pole submerged and the men of TRITON circumnavigating the world submerged.

Yes, these deeds you know of through your training programs, your association with your instructors and other submariners, and from reading books or watching television programs.

But what of the future accomplishments of the Submarine Force?



Today, the number one priority for the development of a weapons system in the Navy has been assigned to the Polaris missile and the nuclear powered FBM submarine that carries it. Can we afford to have anything less than a number one type performance by a number one type man for this system? You, as well as I, know the answer is NO!

The future of the Submarine Force depends on men such as you that are graduating here today. It is true you have far better equipment than those submariners of past decades, but your challenge is also greater.

Just what kind of man is a submariner?

He comes from the cities of America—Los Angeles, Boston, or Chicago or from the small towns of Georgia or Vermont or the farms of Ohio or Texas.

He is interested in boats, or cars, or electronics, or sports, or music, and, of course, girls.

This is his background, varied though it may be. But on the submarine, he is the same as his shipmates.

- He is proud - proud of his ship - his department - and his Dolphins.
- He is enthusiastic - enthusiastic about his work and his qualification in submarines.
- He is ambitious - ambitious in his desire to better himself - to advance in rating and to win his Silver Dolphins.
- He is responsible and reliable - responsible for keeping his equipment in tip-top shape and reliable in times of emergencies.
- He is alert - alert to the possibility of danger that exists aboard a submarine and alert to prevent disaster or at least to minimize it.
- Another trait is that of mutual respect. He respects his shipmates for the knowledge they have of their ship and the responsible way they put this knowledge to work.

These are the kind of men that man our submarines.

How do you become one of these men?

You have already started on the road toward this goal by successfully completing the Basic Submarine Enlisted Course. Of the 349 that entered with this class, 301 have withstood the test. Some of you graduating here today will not measure up to these standards in the future and will be transferred to duty outside the Submarine Force.

The great majority of you that do win your Dolphins will know within yourselves that you have that something that it takes to be a true Submariner.

You will go through the same qualification program that every man now wearing Dolphins has been through.

You will discover that the standards for qualification will not be lowered for anyone. And when you win your Dolphins, see to it that they are not lowered for those who will follow in your footsteps from this school to the boats.

You will find that your new shipmates have a personal interest in your qualification, and for a very good reason - they want to be able to sleep at night confident that you know your job and your ship well enough to perform your watch in a completely reliable manner.

You will find that you are not competing against your classmates, but against a set of rigid standards. Standards that have been developed through many years of submarine experience.

You are not preparing for a quiz to be assigned a mark now, but preparing to meet any emergency as though your life depended upon it. It does!

The majority of you will face the reality that you have never been in such a position of responsibility before in your lives. You are a member of a team. You are a link in a chain - a chain that must remain unbroken in order for the submarine to operate properly. A chain that depends on each link being strong or the chain will not remain unbroken

When you report aboard your submarine, your life will not consist of qualification only - you will be involved in the advancement in rating program. Submarines have a higher percentage of petty officers than any other type of ship in the

Navy. To illustrate this, three years ago when I was skipper of the submarine REMORA in the Pacific, we returned from a seven month cruise to the Far East with 68 of the 72 enlisted men aboard wearing the crow of a petty officer on their sleeves.

Incidentally, on that same cruise, that crew of fine submarine sailors achieved one mark of distinction that other submarine crews may equal, but cannot surpass - every one of them was wearing Silver Dolphins.

Your submarine life will offer other experiences also - you will enjoy the benefits of the old recruiting slogan, "Join the Navy and see the world".

If you go to a Pacific Fleet submarine, you will visit such places as Tokyo, Hong Kong, Manila, Honolulu, Alaska and West Coast ports. Those of you reporting to Atlantic Fleet submarines will visit the Mediterranean, the Caribbean, Scotland and East Coast ports.

To the families of these men graduating here today I would like to say this:

These men need your understanding - your support and your encouragement as they face this new and challenging life of a submariner. Give them this support, understanding and encouragement. It will go a long way toward helping them as they chart their way through the rough seas ahead.

Before closing I would like to extend a very sincere 'Well Done' to the honorman of your class. ... I know the gold watch he will wear on his wrist throughout the years ahead will be more than just a timepiece to him. It will always remind him of the rugged competition he faced from the 298th class as well as remind him of the common bond the members of this graduating class will always have.

Men – *Congratulations.*

Welcome aboard the submarines of our wonderful Submarine Force and — Smooth Sailing!

BOOK REVIEW

**COLD WAR COMMAND:
THE DRAMATIC STORY OF A NUCLEAR SUBMARINER**

*by CAPT Dan Conley, RN,, Ret. OBE and
CAPT Richard Woodman, Merchant Navy, Ret.*

*Published by Seaforth Publishing, Inc., Barnsley, England, UK
ISBN 978-1-471-84832-769-6*

*Reviewed by CAPT Jim Patton, USN, Ret.
Naval Submarine League*

Readers of *Cold War Command* will come away thinking that CAPT Dan Conley has made a career of "speaking truth to power" - a personal trait that many of us would like to think we have. I can attest, however, that Dan really does possess it. As the *duty Brit submariner* at DEVRON 12, then CDR Conley more than once pointed out to the Chief Staff Officer—a certain CAPT Jim Patton—the error of his ways. His input was always valuable, and I soon took to asking "...what do you think about this Dan?" Before I embarrassed myself by voicing my opinion first.

His credibility now established, I can only recommend that any even casual student of the Cold War and of the training, engineering, submarine construction and other facets of that period read his book. He *takes no prisoners* when he speaks of the shortcomings in these areas, including naming names, where appropriate. On the other hand, he heaps praise on people and organizations that clearly merited it.

There are and have been so many *tell-all* books about submarines in the Cold War, from Tom Clancy on down, that those that were in the thick of it have understandably developed a *BS filter* than screens out much of the incredulous or downright lies. If anyone were to suspect that Dan was any less of a submariner than

his book attests, consider for a moment that as the Commanding Officer of one of his two SSN commands, he detected, closed and trailed four different Soviet submarines during one two-week period without being counterdetected. There is little doubt in my mind that the Soviet Navy kept a dossier on Dan's comings and goings.

Some of the material in *Cold War Command* that are worthy of study and reflection include his views on his Navy's failure to keep current tactical training focused on current tactical issues. For example, the hallowed UK PERISHER training focusing almost exclusively on the individualistic, technique-associated skills involved in conducting a WWII-type periscope approach for a short-range, straight-running torpedo attack when the *real* (and largely unaddressed) problem at that time was the procedural and team skill of conducting a long range sonar approach to a point where the solution was *good enough* for a smart weapon to consummate. He is also vociferous in condemning the UK's bureaucratic heavyweight torpedo community for failing to correct (or even notice) serious problems with their *Tigerfish* weapon, shortcomings which were perpetuated into its replacement project, the *Spearfish* torpedo.

US submariners will see many parallels in the UK submarining world that Dan Conley lived through, and also many differences. It gives more food for thought, but doesn't definitively answer the decades-old question of the Brit *split* of Deck Officers and Engineers as opposed to the US *Jack-of-all-trades* approach. His accounts of submarine operations in the Barents are honest and insightful, and his description of shipyard conditions are *spot-on*.

The book could easily have been titled the *Rise and Fall of the British Submarine Force*, since Dan personally experienced the whole affair. He is literally the *Winds of War* Pug Henry, since he was present at and participated in nearly all the major events of his service during the Cold War. This book is not only fascinating for the experienced NATO submariner, but should be required reading for all submarine officer training pipelines.

NAVAL SUBMARINE LEAGUE CORPORATE MEMBERS

Thirty Years or More

American Systems Corporation ★ ★
The Babcock & Wilcox Company ★ ★ ★ ★ ★
General Dynamics Electric Boat ★ ★ ★ ★ ★
Huntington Ingalls Inc.—NNS ★ ★ ★ ★ ★
Raytheon Company ★ ★ ★ ★ ★
Treadwell Corporation ★
Ultra Electronics Ocean Systems, Inc. ★ ★
URS Federal Services ★ ★ ★

Twenty Five Years or More

Applied Mathematics, Inc. ★
Boeing ★ ★
DRS Technologies, Maritime and Combat Support Systems ★ ★ ★
General Dynamics Advanced Information Systems ★ ★ ★ ★
Lockheed Martin Corporation ★ ★ ★ ★ ★
RIX Industries ★
SAIC ★
Sonalysts, Inc. ★ ★
Systems Planning and Analysis, Inc. ★ ★

Twenty Years or More

AMADIS, Inc. ★
Dell Services Federal Government ★ ★ ★ ★
Northrop Grumman Navigation and Maritime Systems ★ ★ ★ ★ ★
Sargent Aerospace & Defense ★

Fifteen Years or More

Alion Science & Technology ★ ★
Battelle ★ ★ ★ ★
Curtiss-Wright Flow Control Company ★ ★ ★



Ten Years or More

Cunico Corporation & Dynamic Controls ★ ★
Dresser-Rand Company ★
L-3 Communications Corporation ★ ★ ★ ★ ★
Pacific Fleet Submarine Memorial Association, Inc. ★
Progeny Systems Corporation ★ ★ ★
UTC Aerospace Systems ★ ★

Five Years or More

3 Phoenix, Inc. ★
AMI International ★
CACI International Inc. ★
Imes ★
In-Depth Engineering Corporation ★
Micropore, Inc. ★
Nord-Lock/Superbolt, Inc. ★
Nuclear Fuel Services, Inc. ★ ★
Oceaneering International, Inc. ★ ★ ★
Securitas Critical Infrastructure Services, Inc. ★ ★
Siemens, PLM Software ★
TSM Corporation ★ ★ ★
VCR, Inc. ★

Additional Corporate Members

Adaptive Methods, Inc. (new in 2014) ★
Advanced Acoustic Concepts, LLC ★ ★
Applied Physical Sciences Corporation ★
Applied Research Laboratory—Penn State (new in 2014) ★
BAE Systems Integrated Technical Solutions ★ ★
Capitol Integration (new in 2014) ★
CEPEDA Associates, Inc. ★
C.S. Draper Laboratory, Inc. ★
Garvey Precision Machine, Inc. (new in 2014) ★
General Atomics ★ ★
Innovative Defense Technologies ★ ★
Marrotta Controls (new in 2014) ★ ★
Murray Guard, Inc. ★

OceanWorks International (new in 2014) ★
Precision Defense Services (new in 2014) ★
Preferred Systems Solutions, Inc. ★
SeaBotix, Inc. (new in 2014) ★
Seawolf Solutions, Inc. (new in 2014) ★
Security Technologies International ★
TASC, Inc. ★★★
USAA ★★★

CORPORATE DUES

★★★★★ = 5 Star Level (\$10,000 +) ★★ = 2 Star Level (\$2,500 +)
★★★★ = 4 Star Level (\$7,500 +) ★ = 1 Star Level (\$1,000 +)
★★★ = 3 Star Level (\$5,000 +)



NAVAL SUBMARINE LEAGUE

LIFE MEMBERS

CAPT David A. Adams, USN
Mr. William L. Ace
CDR Dwight Alexander, USN, Ret.
CMDM(SS) Eric Antoine, USN
Mrs. Ingrid Beach
CDR R. M. Berry, USN, Ret.
CAPT Patrick Bloomfield, USN, Ret.
Mr. Frank Campbell
CAPT Gard Clark, USN, Ret.
RADM Phil Davis, USN, Ret.
MCPON Brad Gill, USN
FRCS(SS) James M. Hendrix,
USN, Ret.
RADM Joseph "Joe" Henry, USN, Ret.
Mr. David A. Horvath
LCDR Franklin G. King, USN, Ret.
VADM Albert H. Konetzni, Jr.,
USN, Ret.
LCDR George W. Palmer, USN, Ret.
LCDR Tim Michael Maloney,
USN, Ret.
Mr. Thomas Meaney
Mr. David Murphy
Mr. Tim Richard
EMCS(SS) Michael D. Schulte,
USN, Ret.
Mr. Thomas White

SPONSOR

RADM John B. Padgett III, USN, Ret.

SKIPPER

CAPT William P. Bancroft, USN, Ret.
Mr. Joseph Buff
ADM Henry G. Chiles, USN, Ret.
CAPT Frederick J. Kollmorgen,
USN, Ret.
CAPT David L. Self, USN, Ret.

ADVISOR

CAPT Earl Griggs, USN, Ret.
RADM John Koenig, USN, Ret.
CAPT Kent R. Siegel, USN, Ret.

ASSOCIATE

CAPT Arthur H. Gilmore, USN, Ret.

ETERNAL PATROL

CAPT Marvin S. Blair, USN, Ret.
CDR James L. Ferro, USN, Ret.
CAPT George M. Henson, USN, Ret.
VADM Gerald E. Miller, USN, Ret.
Mr. John Lovasz
STS2(SS) Frank C. Sebesta, USN, Ret.
LT. Howard M. Striver, USN, Ret.
CAPT Robert T. Styer, USN, Ret.
CAPT Herbert D. Trenham, USN, Ret.



Naval Submarine League
 5025D Backlick Road
 Annandale, VA 22003
 Tel: 703-256-0891 • Fax: 703-642-5815
 www.navalsubleague.com



"The Second Hundred Years"

MEMBERSHIP APPLICATION FORM

Name: _____ Birth Year: _____

Rank/Rate, Service (if applicable): _____

Duty Station (if applicable): _____

Preferred Mailing Address: _____

Telephone Number (H/O/C): _____
Circle one

E-mail (Home): _____ (Office): _____

THIS SECTION MUST BE COMPLETED BEFORE YOUR APPLICATION WILL BE PROCESSED

I hereby apply for membership in THE NAVAL SUBMARINE LEAGUE. I certify that I am a citizen of the United States or a citizen of _____ . I also certify (check one) that _____ I do not or _____ I do act as an agent, representative, employee (includes active duty military), or in any other capacity, at the order request or under the direction or control of the government of a foreign country or a foreign political party. If "I do" is checked above, a brief description of the foreign affiliation must be provided with the application.

Signature: _____

NAVAL SUBMARINE LEAGUE MEMBERSHIP APPLICATION

ELECTRONIC REVIEW MEMBERSHIP

The following Membership levels include only the electronic version of *The Submarine Review*.

Please check the applicable membership level:

Active Duty E1-E3 or Officer Student (e.g., USNA, NROTC, SOBC, NPS, NPTU) Initial: Free for 2 years

Active E4-E6/O1-O3 3 Years \$15.00

Active, Reserve, Ret., Civilian E7-E9/O4-O10 3 Years \$30.00

OR LIFE MEMBERSHIP with electronic version of *The Submarine Review*. (Life membership may be paid in 5 equal installments)

Age 39 and younger \$250.00

Age 40-59 \$200.00

Age 60+ \$150.00

PRINTED REVIEW MEMBERSHIP

The following Membership levels include the printed version of *The Submarine Review*.

Please check the applicable membership level:

REGULAR MEMBERSHIP* \$35.00 For 1 Year \$90.00 For 3 Years

*Persons residing outside the United States are required to remit an additional \$20.00 PER YEAR for mailing costs.

OR LIFE MEMBERSHIP (Life memberships may be paid in 5 equal annual installments)

Age 39 and younger: \$500.00

Age 40-59: \$400

Age 60 and older: \$300.00

PAYMENT

CHECK

VISA/MASTERCARD

I would like to request automatic membership renewal

VISA/MASTERCARD #: _____ Amount to be charged: \$ _____

Exp. Date: _____ / _____

Security Code: _____

Signature: _____

MORE

The Virginia Class Block III Brings More To The US Navy

More versatility for the US Navy. More options for the commander. More payload space. How do you deliver more for less? Visit our website and we'll explain how we delivered the North Dakota on time and under target cost with improvements that make her the most capable submarine in the history of the US Navy. Free limited edition poster of this ad. Email Greg Rose at grose1@gdeb.com.

GENERAL DYNAMICS
Electric Boat
www.gdeb.com

